



Screwdriving technology

Automation

Air motors

Air tools

# DEPRAG

**NEW**

## Stationary Control Screwdriver Spindles Angle Head Design

with integrated Function Control  
from 0.3 - 67 Nm / 2.7 to 593 in.lbs

- **Extreme high Torque Accuracy and Repeatability**
- **For tight Assembly Areas**
- **Long life, low noise**
- **Simple integration**

The DEPRAG Control Screwdrivers assemble screws to torque and measure that torque more accurately than any subsequent testing. They tighten and test the assembly in one operation.

The screw joint, hard or soft, and air pressure fluctuations have no influence on the MINIMAT clutch. The torque of the spindle can be pre set.

Control Screwdrivers with angle head design are available in right rotation and reversible. These tools can be used without lubrication: This should however only be done in specific applications. Using a tool without lubrication will decrease it's lifespan.

The DEPRAG stationary control screwdriver spindles with angle head design are preferably used for assemblies in tight areas.

Motor Size 2

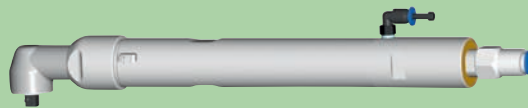

Motor Size 3

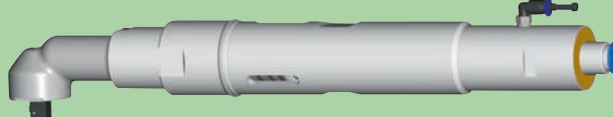

Motor Size 4



## Technical Data

Screwdriver Style		Motor Size 2		
Spindle right rotation Remote Start	<b>Type</b> order no.	<b>377-320-7-E6.3</b> 200616 B	<b>377-420-7-E6.3</b> 200616 D	<b>377-520-7-E6.3</b> 200616 C
Spindle end Suitable tool inserts with		External Square Drive DIN 3121 - E6.3 (1/4") Internal Square Drive DIN 3121 - G6.3 (1/4")		
Spindle right rotation Remote Start	<b>Type</b> order no.	<b>377-320-7-F6.3</b> 2006161B	<b>377-420-7-F6.3</b> 2006161D	<b>377-520-7-F6.3</b> 2006161C
Spindle end Suitable tool inserts with		Internal hex. Drive DIN 3126 - F6.3 (1/4") with quick change chuck External hex. Drive DIN 3126 - E6.3 (1/4")		
Torque min.	Nm / in.lbs	0.4 / 3.5	0.4 / 3.5	0.3 / 2.7
Torque max.	Nm / in.lbs	3.6 / 31.9	4.5 / 39.8	6.5 / 57.5
Speed idling	rpm	1070	710	470
Air consumption	m <sup>3</sup> /min / cfm	0.3 / 11	0.3 / 11	0.3 / 11
Weight	kg / lbs	0.9 / 2	0.9 / 2	0.9 / 2
Hose for air supply (O.D./I.D.)	mm / in.	8 / 5.5 (.314 <sup>7</sup> / <sub>32</sub> )	8 / 5.5 (.314 <sup>7</sup> / <sub>32</sub> )	8 / 5.5 (.314 <sup>7</sup> / <sub>32</sub> )
Hose for function control (O.D./I.D.)	mm / in.	4 / 2.5 (.157 <sup>3</sup> / <sub>32</sub> )	4 / 2.5 (.157 <sup>3</sup> / <sub>32</sub> )	4 / 2.5 (.157 <sup>3</sup> / <sub>32</sub> )
Noise level	dB (A)	71	71	71

Screwdriver Style		Motor Size 2		
Spindle reversible Remote Start	<b>Type</b> order no.	<b>377-320-7U-E6.3</b> 200633 B	<b>377-420-7U-E6.3</b> 200633 D	<b>377-520-7U-E6.3</b> 200633 C
Spindle end Suitable tool inserts with		External Square Drive DIN 3121 - E6.3 (1/4") Internal Square Drive DIN 3121 - G6.3 (1/4")		
Spindle reversible Remote Start	<b>Type</b> order no.	<b>377-320-7U-F6.3</b> 2006331B	<b>377-420-7U-F6.3</b> 2006331D	<b>377-520-7U-F6.3</b> 2006331C
Spindle end Suitable tool inserts with		Internal hex. Drive DIN 3126 - F6.3 (1/4") with quick change chuck External hex. Drive DIN 3126 - E6.3 (1/4")		
Torque min.	Nm / in.lbs	0.4 / 3.5	0.4 / 3.5	0.3 / 2.7
Torque max.	Nm / in.lbs	3.6 / 31.9	4.5 / 39.8	6.5 / 57.5
Speed idling	rpm	840	710	360
Air consumption	m <sup>3</sup> /min / cfm	0.3 / 11	0.3 / 11	0.3 / 11
Weight	kg / lbs	0.93 / 2	0.93 / 2	0.93 / 2
Hose for air supply (O.D./I.D.)	mm / in.	8 / 5.5 (.314 <sup>7</sup> / <sub>32</sub> )	8 / 5.5 (.314 <sup>7</sup> / <sub>32</sub> )	8 / 5.5 (.314 <sup>7</sup> / <sub>32</sub> )
Hose for function control (O.D./I.D.)	mm / in.	4 / 2.5 (.157 <sup>3</sup> / <sub>32</sub> )	4 / 2.5 (.157 <sup>3</sup> / <sub>32</sub> )	4 / 2.5 (.157 <sup>3</sup> / <sub>32</sub> )
Noise level	dB (A)	71	71	71

Performance data relate to an air pressure of 6.3 bar (90 psi)

Please find suitable accessories on page 7.

Please also find suitable tool inserts in our brochure D 3320 E.

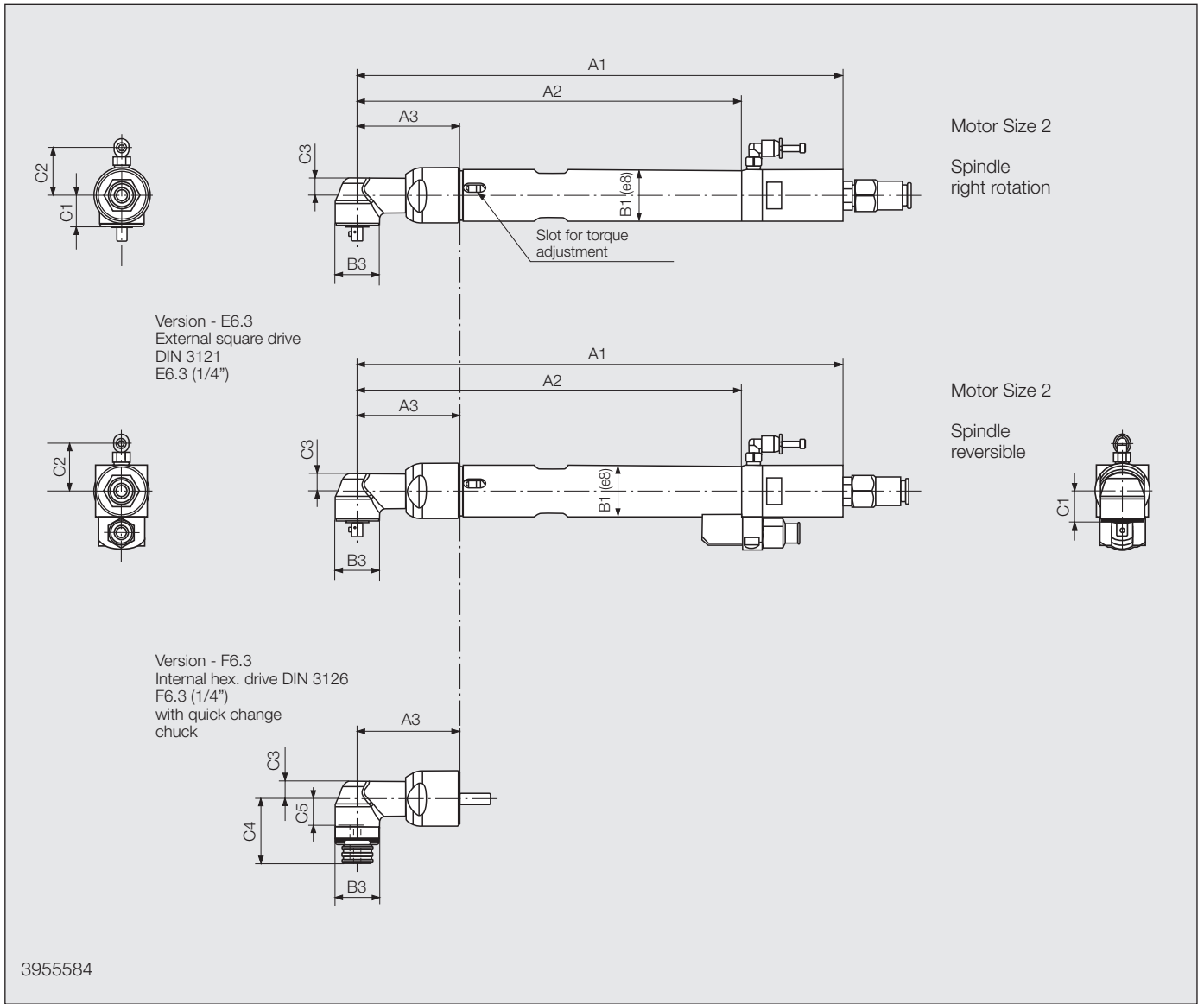

<b>Motor Size 2</b>			Dimensions (mm)									
Type			A1	A2	A3	B1	B3	C1	C2	C3	C4	C5
Spindle right rotation												
377-320-7-E6.3	377-420-7-E6.3	377-520-7-E6.3	263.2	208.2	55.4	27	24	17.1	25.5	9.5	35.1	14.1
377-320-7-F6.3	377-420-7-F6.3	377-520-7-F6.3										
Spindle reversible												
377-320-7U-E6.3	377-420-7U-E6.3	377-520-7U-E6.3	263.2	208.2	55.4	27	24	17.1	25.5	9.5	35.1	14.1
377-320-7U-F6.3	377-420-7U-F6.3	377-520-7U-F6.3										

## Technical Data

Screwdriver Style		Motor Size 3			
Spindle right rotation Remote Start	<b>Type</b> order no.	<b>377-230-7-E10</b> 200941 B	<b>377-730-7-E10</b> 200941 C	<b>377-330-7-E10</b> 200941 D	<b>377-430-7-E10</b> 200941 E
Spindle end Suitable tool inserts with		External Square Drive DIN 3121 - E10 (3/8") Internal Square Drive DIN 3121 - G10 (3/8")			
Torque min.	Nm / in.lbs	4 / 35.4	4 / 35.4	4 / 35.4	4 / 35.4
Torque max.	Nm / in.lbs	7 / 62	12 / 106.2	20 / 177	35 / 309.8
Speed idling	rpm	1500	840	450	240
Air consumption	m <sup>3</sup> /min / cfm	0.45 / 16	0.45 / 16	0.45 / 16	0.45 / 16
Weight	kg / lbs	1.9 / 4.2	1.9 / 4.2	1.9 / 4.2	1.9 / 4.2
Hose for air supply (O.D./I.D.)	mm / in.	10 / 7 (3/8/.273)	10 / 7 (3/8/.273)	10 / 7 (3/8/.273)	10 / 7 (3/8/.273)
Hose for function control (O.D./I.D.)	mm / in.	4 / 2.5 (.157 <sup>3</sup> /32)	4 / 2.5 (.157 <sup>3</sup> /32)	4 / 2.5 (.157 <sup>3</sup> /32)	4 / 2.5 (.157 <sup>3</sup> /32)
Noise level	dB (A)	79	79	79	79

Screwdriver Style		Motor Size 3			
Spindle reversible Remote Start	<b>Type</b> order no.	<b>377-230-7U-E10</b> 200619 B	<b>377-730-7U-E10</b> 200619 C	<b>377-330-7U-E10</b> 200619 D	<b>377-430-7U-E10</b> 200619 E
Spindle end Suitable tool inserts with		External Square Drive DIN 3121 - E10 (3/8") Internal Square Drive DIN 3121 - G10 (3/8")			
Torque min.	Nm / in.lbs	4 / 35.4	4 / 35.4	4 / 35.4	4 / 35.4
Torque max.	Nm / in.lbs	6.5 / 57.5	10 / 88.5	19 / 168.2	32 / 283.2
Speed idling	rpm	1400	730	365	190
Air consumption	m <sup>3</sup> /min / cfm	0.45 / 16	0.45 / 16	0.45 / 16	0.45 / 16
Weight	kg / lbs	2.15 / 4.7	2.15 / 4.7	2.15 / 4.7	2.15 / 4.7
Hose for air supply (O.D./I.D.)	mm / in.	10 / 7 (3/8/.273)	10 / 7 (3/8/.273)	10 / 7 (3/8/.273)	10 / 7 (3/8/.273)
Hose for function control (O.D./I.D.)	mm / in.	4 / 2.5 (.157 <sup>3</sup> /32)	4 / 2.5 (.157 <sup>3</sup> /32)	4 / 2.5 (.157 <sup>3</sup> /32)	4 / 2.5 (.157 <sup>3</sup> /32)
Noise level	dB (A)	79	79	79	79

Performance data relate to an air pressure of 6.3 bar (90 psi)

Please find suitable accessories on page 7.

Please also find suitable tool inserts in our brochure D 3320 E.

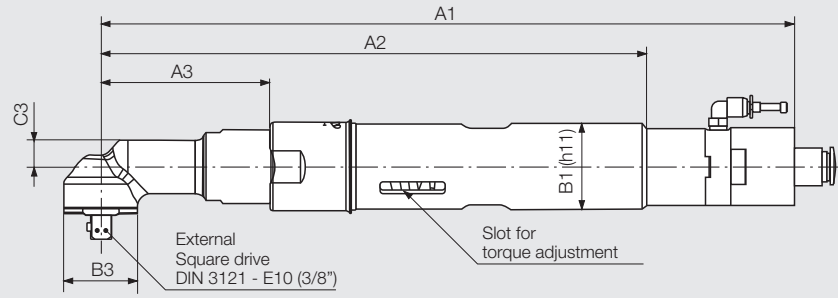
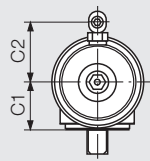

Motor Size 3  
Spindle  
right rotation

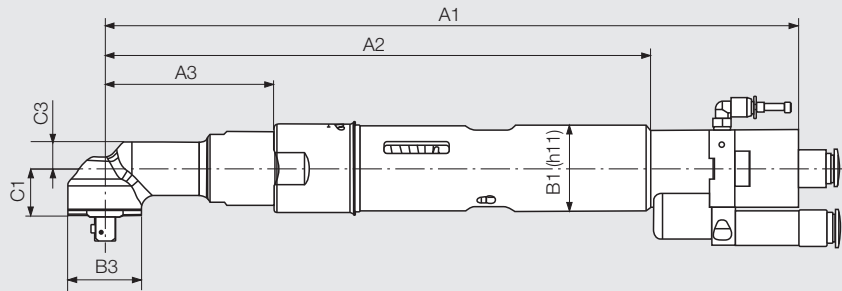
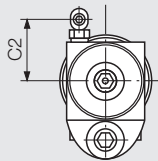

Motor Size 3  
Spindle  
reversible

2009421

Motor Size 3								
Type	Dimensions (mm)							
	A1	A2	A3	B1	B3	C1	C2	C3
Spindle right rotation								
377-230-7-E10								
377-730-7-E10	324.3	255.3	78.9	40	34.5	22.6	28	12.5
377-330-7-E10								
377-430-7-E10								
Spindle reversible								
377-230-7U-E10								
377-730-7U-E10	324.3	255.3	78.9	40	34.5	22.6	28.5	12.5
377-330-7U-E10								
377-430-7U-E10								

# Technical Data

Screwdriver Style		Motor Size 4			
		right rotation		reversible	
Spindle Remote Start	Type order no.	<b>377-740-7-E12.5</b> 200662 C	<b>377-840-7-E12.5</b> 200662 D	<b>377-740-7U-E12.5</b> 200671 C	<b>377-840-7U-E12.5</b> 200671 D
Spindle end Suitable tool inserts with		External Square Drive DIN 3121 - E12.5 (1/2") Internal Square Drive DIN 3121 - G12.5 (1/2")			
Torque min.	Nm / in.lbs	20 / 177	20 / 177	15 / 132.8	15 / 132.8
Torque max.	Nm / in.lbs	48 / 424.8	67 / 593	46 / 407.1	65 / 575.3
Speed idling	rpm	390	270	300	220
Air consumption	m <sup>3</sup> /min / cfm	1.1 / 38.8	1.1 / 38.8	1.1 / 38.8	1.1 / 38.8
Weight	kg / lbs	2.7 / 5.9	2.7 / 5.9	3.1 / 6.8	3.1 / 6.8
Hose for air supply (O.D./I.D.)	mm / in.	12 / 8 (.472 <sup>5/16</sup> )	12 / 8 (.472 <sup>5/16</sup> )	12 / 8 (.472 <sup>5/16</sup> )	12 / 8 (.472 <sup>5/16</sup> )
Hose for function control (O.D./I.D.)	mm / in.	4 / 2.5 (.157 <sup>3/32</sup> )	4 / 2.5 (.157 <sup>3/32</sup> )	4 / 2.5 (.157 <sup>3/32</sup> )	4 / 2.5 (.157 <sup>3/32</sup> )
Noise level	dB (A)	78	78	80	80

Performance data relate to an air pressure of 6.3 bar (90 psi)

Please find suitable accessories on page 7.

Please also find suitable tool inserts in our brochure D 3320 E.

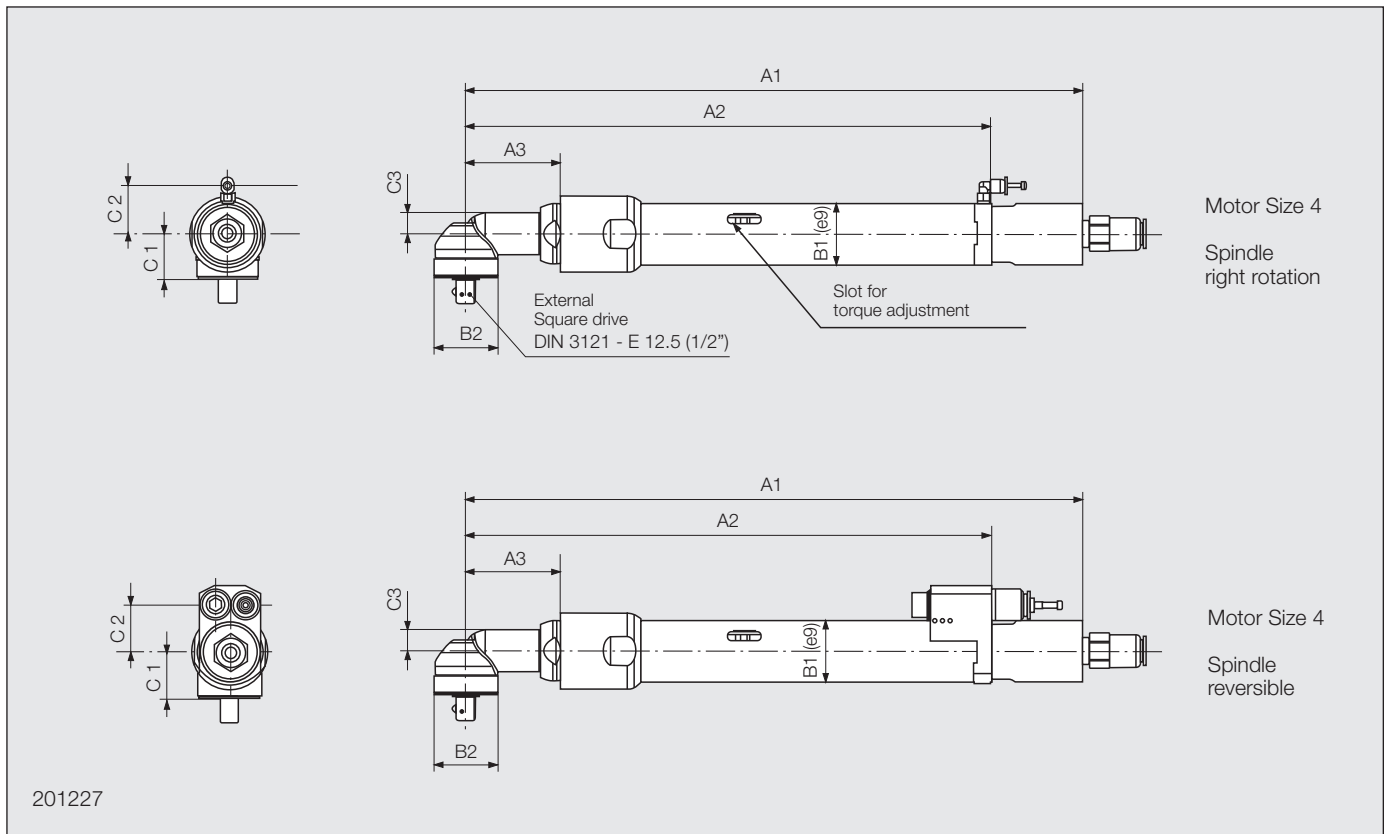

Motor Size 4								
Type	Dimensions (mm)							
Spindle right rotation	A1	A2	A3	B1	B2	C1	C2	C3
377-740-7-E12.5	401	341	61.5	40	41	29.5	30.5	13.8
377-840-7-E12.5								
Spindle reversible	401	341	61.5	40	41	29.5	30.5	13.8
377-740-7U-E12.5								
377-840-7U-E12.5								

# Accessories

**Standard Equipment:** Set of Coupler and Connector Plugs · Set of Torque and Adjustment Tools · Set of Clutch Springs

# Optional Equipment

		Motor Size 2	Motor Size 3 right rotation / reversible	Motor Size 4
Exhaust connection in line with spindle	order no.	386924 A	386924 A / 386924 C	351820 R
90° in relation to spindle	order no.	386924 B	386924 B / 386924 D	351820 U

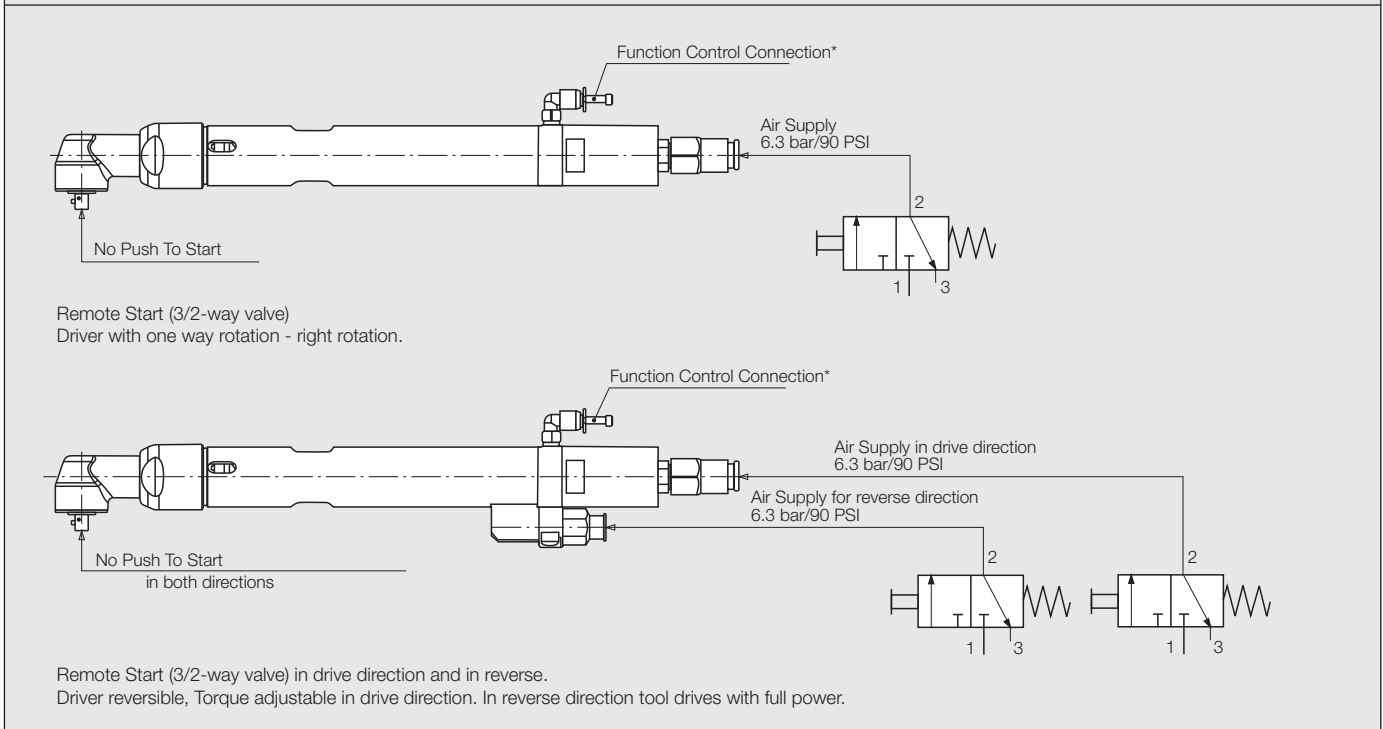
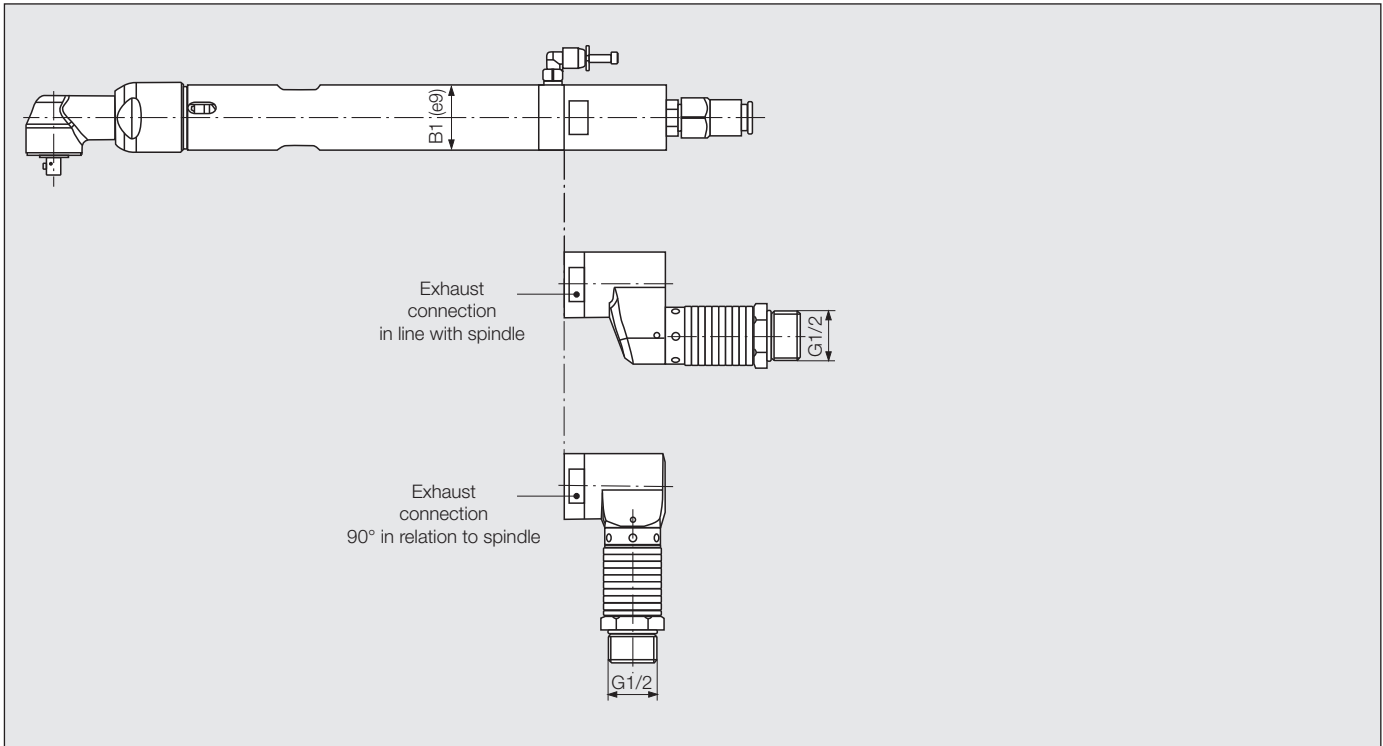

\*) During drive cycle the Function Control Line is under pressure (approx. 2 bar).

# DEPRAG

**DEPRAG SCHULZ GMBH u. CO.**

P.O. Box 1352, D-92203 Amberg, Germany  
Kurfürstenring 12-18, D-92224 Amberg  
Phone (096 21) 371-0, Fax (096 21) 371-120  
[www.deprag.com](http://www.deprag.com)  
[info@deprag.de](mailto:info@deprag.de)



CERTIFIED AS PER DIN EN ISO 9001

---