



Screwdriving technology

Automation

Air motors

Air tools

# DEPRAG



## Air-Vane Motors

from 1.6 to 18 kW / 2.1 to 24 HP

- robust
- powerful
- durable

We offer interesting alternatives for the drive- and control tasks of all industry branches, with our powerful and versatile Air-Vane Motors of the design series from 1.6 to 18 kW. The high start torque, the smallest weight to power output ratio, and the robust and reliable design, are the main advantages compared to an electric drive. All motors include the well known high durability and precision of all DEPRAG air tools. For more details, please see leaflet D 6000 E.

We offer relating accessories, such as maintenance units, special lubrication oil for air tools and oil-resistant pressure hoses (3340 E).



### Air-Vane Motor

power- and torque characteristics

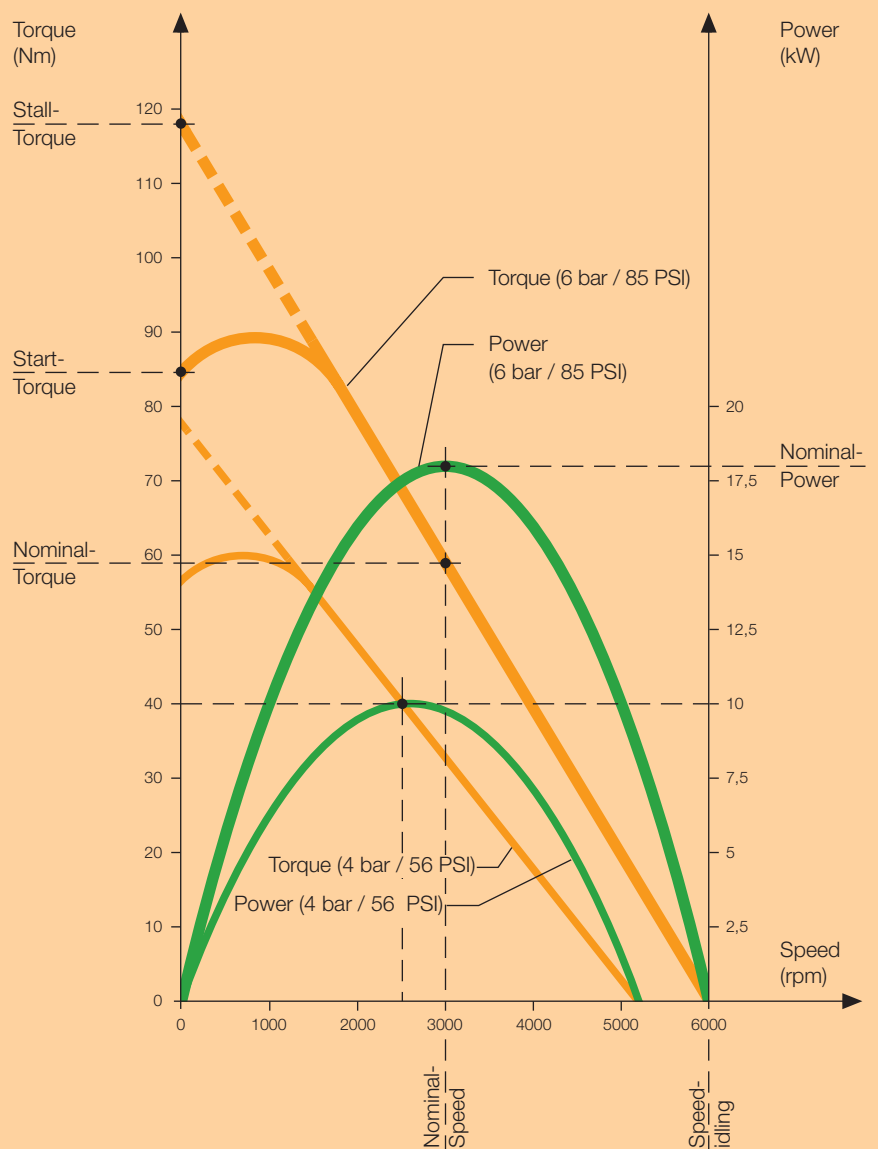

## Technical Data

The motors in this design series can be operated in either right- or left rotation.

Alternatively, the motor can also be reversed by two external 3/2-way valves or one 5/3-way valve (each with sufficiently large cross-sections).

<b>Motor Size 9</b> without Gearing		<b>Flange motor</b>	
Motor, reversible by external valve	<b>type</b> oder no.	<b>68-009 / IEC 71 A</b> 445478 A	
Nominal-Power	kW / HP	1.6 / 2.1	
Nominal-Speed	rpm	4500	
Speed (idling)	rpm	9000	
Nominal-Torque	Nm / in.lbs	3.3 / 29	
Start-Torque min.	Nm / in.lbs	5 / 44	
Radial force max.	N / lbs	1000 / 220	
Axial force max.	N / lbs	600 / 130	
Air Consumption	m <sup>3</sup> /min / cfm	1.9 / 67	
Weight	kg / lbs	4.2 / 9	
Hose I. D.	mm / in.	15 / 5/8	

Performance data relate to an air pressure of 6 bar (85 PSI)

<b>Motor Size 9</b> with Planetary-Gear		<b>Flange motor</b>			
Motor, reversible by external valve	<b>type</b> order no.	<b>68 - P005F - 000 - 09</b> 444844 A	<b>68 - P010F - 000 - 09</b> 444844 B	<b>68 - P025F - 000 - 09</b> 444844 C	<b>68 - P050F - 000 - 09</b> 444844 D
Nominal-Power	kW / HP	1.6 / 2.1	1.6 / 2.1	1.6 / 2.1	1.6 / 2.1
Nominal-Speed	rpm	900	450	180	90
Speed (idling)	rpm	1200 *)	600 *)	190 *)	95 *)
Nominal-Torque	Nm / in.lbs	16 / 141	32 / 283	77 / 681	100 / 885 <sup>1)</sup>
Start-Torque min.	Nm / in.lbs	24 / 212	48 / 425	115 / 1018	100 / 885 <sup>1)</sup>
Radial force max.	N / lbs	2400 / 530	2400 / 530	4600 / 1020	4600 / 1020
Axial force max.	N / lbs	1900 / 420	1900 / 420	4000 / 890	4000 / 890
Air Consumption	m <sup>3</sup> /min / cfm	1.9 / 67	1.9 / 67	1.9 / 67	1.9 / 67
Weight	kg / lbs	8.3 / 18	8.3 / 18	15.4 / 34	15.4 / 34
Hose I. D.	mm / in.	15 / 5/8	15 / 5/8	15 / 5/8	15 / 5/8
Gear type		P90F	P90F	P120F	P120F
Max. gear torque for permanent load	Nm / in.lbs	40 / 354	35 / 310	100 / 885	100 / 885 <sup>1)</sup>

Performance data relate to an air pressure of 6 bar (85 PSI)

\*) max. admissible Speed (idling)

<sup>1)</sup> Maximum torque 480 Nm for a maximum of 1000 cycles under load.

### Model Number Description

i.e.: 68 - P 005 F - 000 - 09

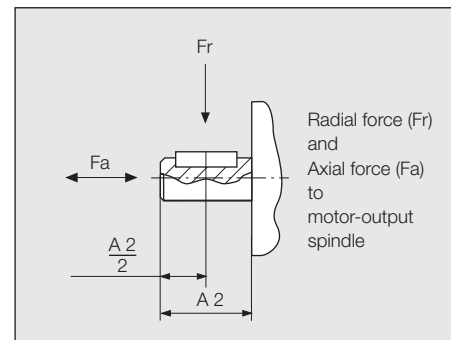
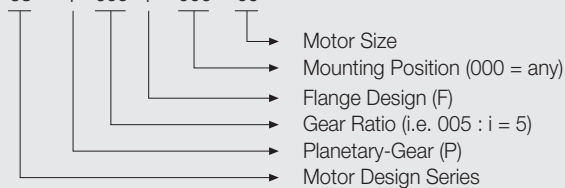

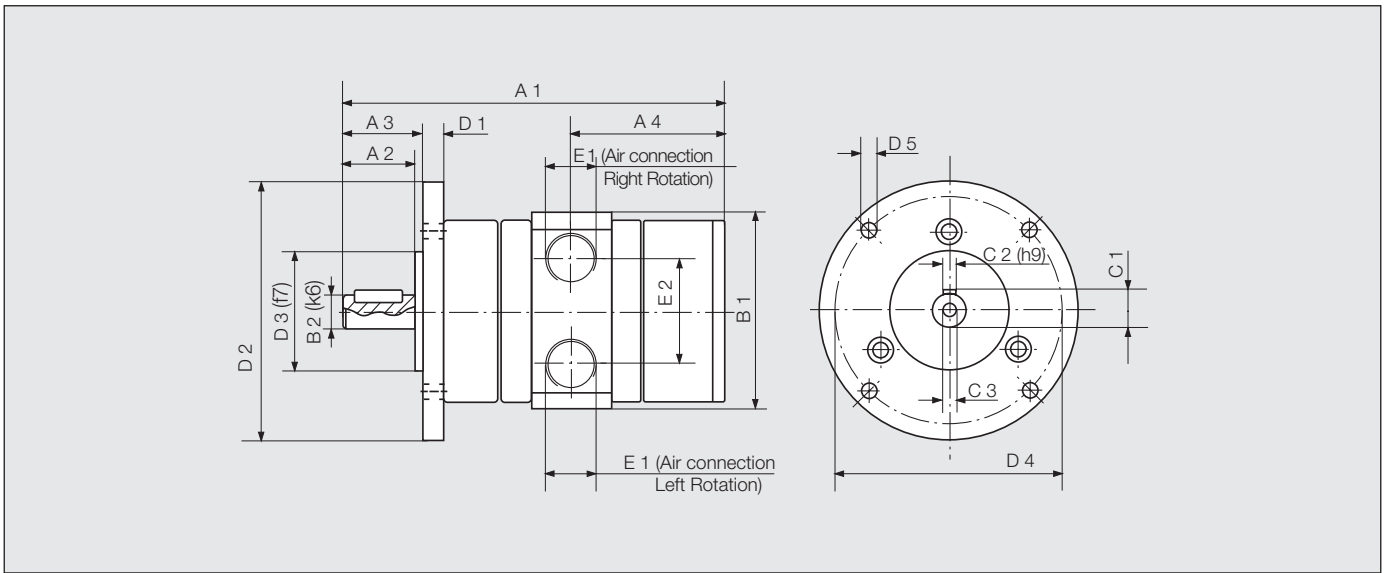

Motor Size 9 without Gearing																
Type	Dimensions of Flange motor (mm)															
	A1	A2	A3	A4	B1	B2	C1	C2	C3	D1	D2	D3	D4	D5	E1	E2
68-009 / IEC 71 A	157	26.5	30	64	85	14	16	5	M6	10	160	110	130	9	1/2"	44

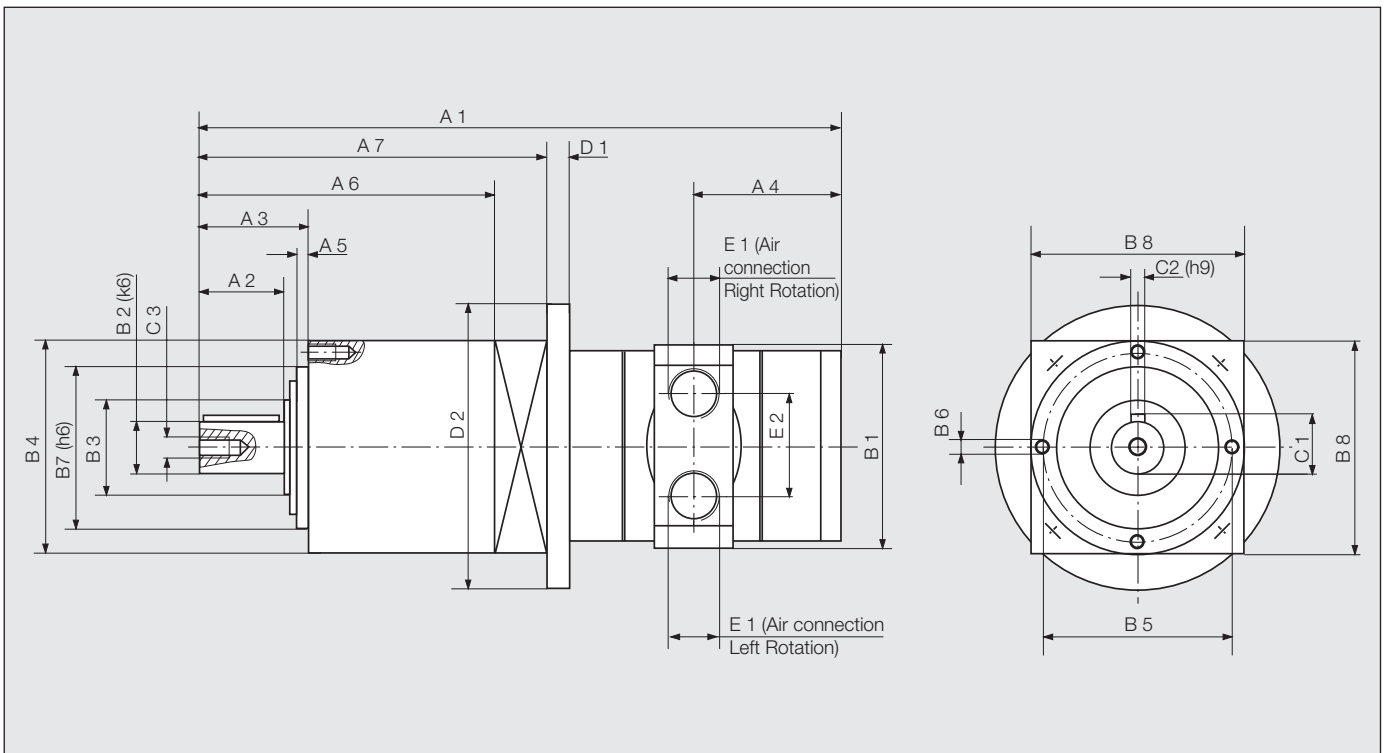

Motor Size 9 with Planetary-Gear													
Type	Dimensions of Flange motor (mm)												
	A1	A2	A3	A4	A5	A6	A7	B1	B2	B3	B4		
68-P005F-000-09	68-P010F-000-09	275	36	46	64	5	126	148	85	22	40	90	
68-P025F-000-09	68-P050F-000-09	359	58	70	64	6	205	233	85	32	50	120	

Motor Size 9 with Planetary-Gear													
Type	Dimensions of Flange motor (mm)												
	B5	B6	B7	B8	C1	C2	C3	D1	D2	E1	E2		
68-P005F-000-09	68-P010F-000-09	80	M6	68	120	24.5	6	M8	10	160	1/2"	44	
68-P025F-000-09	68-P050F-000-09	108	M6	90	120	35	10	M12	10	160	1/2"	44	

## Technical Data

The motors in this design series can be operated in either right- or left rotation. Alternatively, the motor can also be reversed by two external 3/2-way valves or one 5/3-way valve (each with sufficiently large cross-sections).

<b>Motor Size 9</b> with Worm-Gear		<b>Flange motor</b>	<b>Bracket motor</b>
Motor, reversible by external valve	<b>type</b> order no.	<b>68-W014</b> <b>F1- . . . -09</b> 444858 A - F <sup>1)</sup>	<b>68-W014</b> <b>KA- . . . -09</b> 444862 A - F <sup>1)</sup>
Nominal-Power	kW / HP	1.6 / 2.1	1.6 / 2.1
Nominal-Speed	rpm	320	320
Speed (idling)	rpm	430 <sup>2)</sup>	430 <sup>2)</sup>
Nominal-Torque	Nm / in.lbs	38 / 336	38 / 336
Start-Torque min.	Nm / in.lbs	40 / 354	40 / 354
For permissible radial and axial forces please check "optional accessories" on page 28			
Air-Consumption	m <sup>3</sup> /min / cfm	1.9 / 67	1.9 / 67
Weigth	kg / lbs	7.2 / 16	7.2 / 16
Hose I. D.	mm / in.	15 / <sup>5</sup> / <sub>8</sub>	15 / <sup>5</sup> / <sub>8</sub>
Gear type		W49F	W49KA
Max. gear torque for permanent load	Nm / in.lbs	44 / 389	44 / 389

Performance data relate to an air pressure of 6 bar (85 PSI)

<sup>1)</sup> A / B / C / D / E / F = mounting position 0B3 / 0B6 / 0B7 / 0B8 / 0V5 / 0V6  
(Example: mounting position 0B6 = order no. XXXXXX B)  
<sup>2)</sup> max. admissible Speed (idling)

### Model Number Description (when ordering please indicate model designation)

i.e.: 68 - W 014 F1 - 0B3 - 09

- Motor Size
- Mounting Position, see Page 26 (determined by customer)
- Flange Design (F1 / F2), see Page 26 (determined by customer)
- Bracket Design (KA)
- Gear Ratio (i.e. 014 : i = 14)
- Worm-Gear (W)
- Motor Design Series

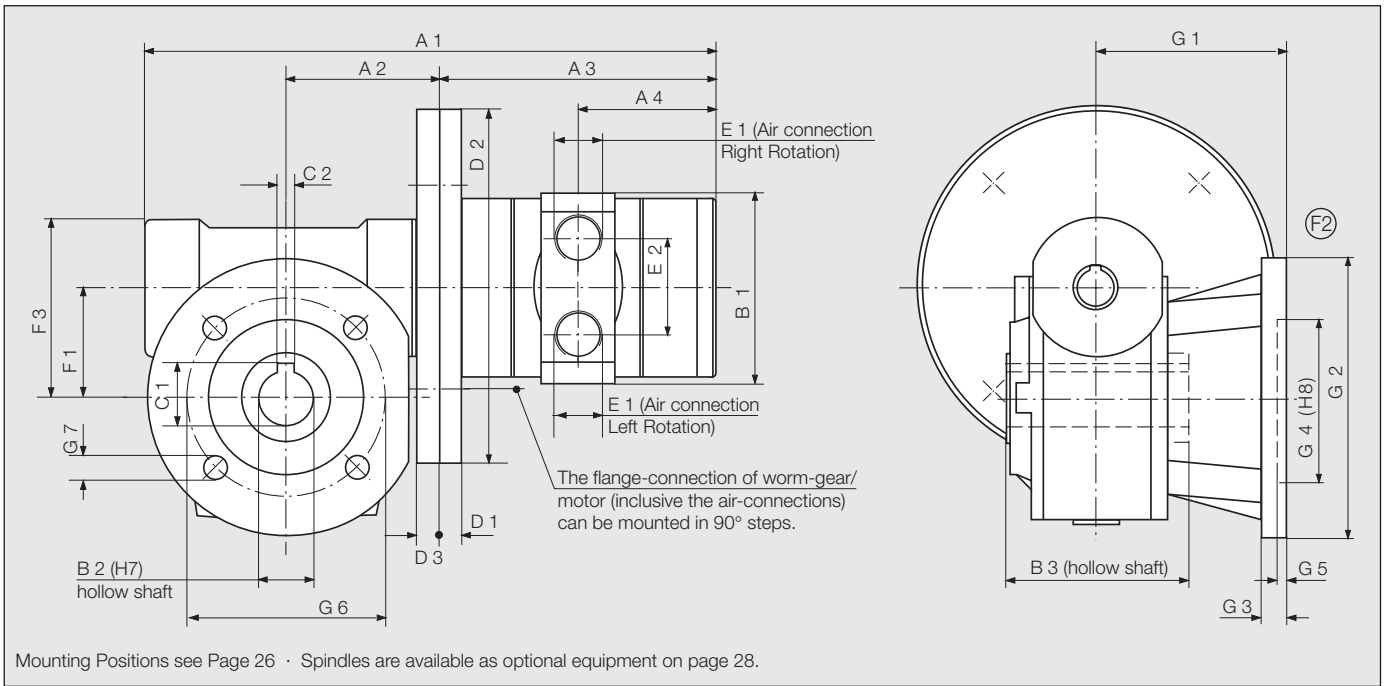

Motor Size 9 with Worm-Gear		Dimensions of Flange motor (mm)																						
Type		A1	A2	A3	A4	B1	B2	B3	C1	C2	D1	D2	D3	E1	E2	F1	F3	G1	G2	G3	G4	G5	G6	G7
68-W014..		260	70	127	64	85	25	82	28.3	8	10	160	10.5	1/2"	44	49.5	80	85	125	12	70	10	90	10.5 (4x)

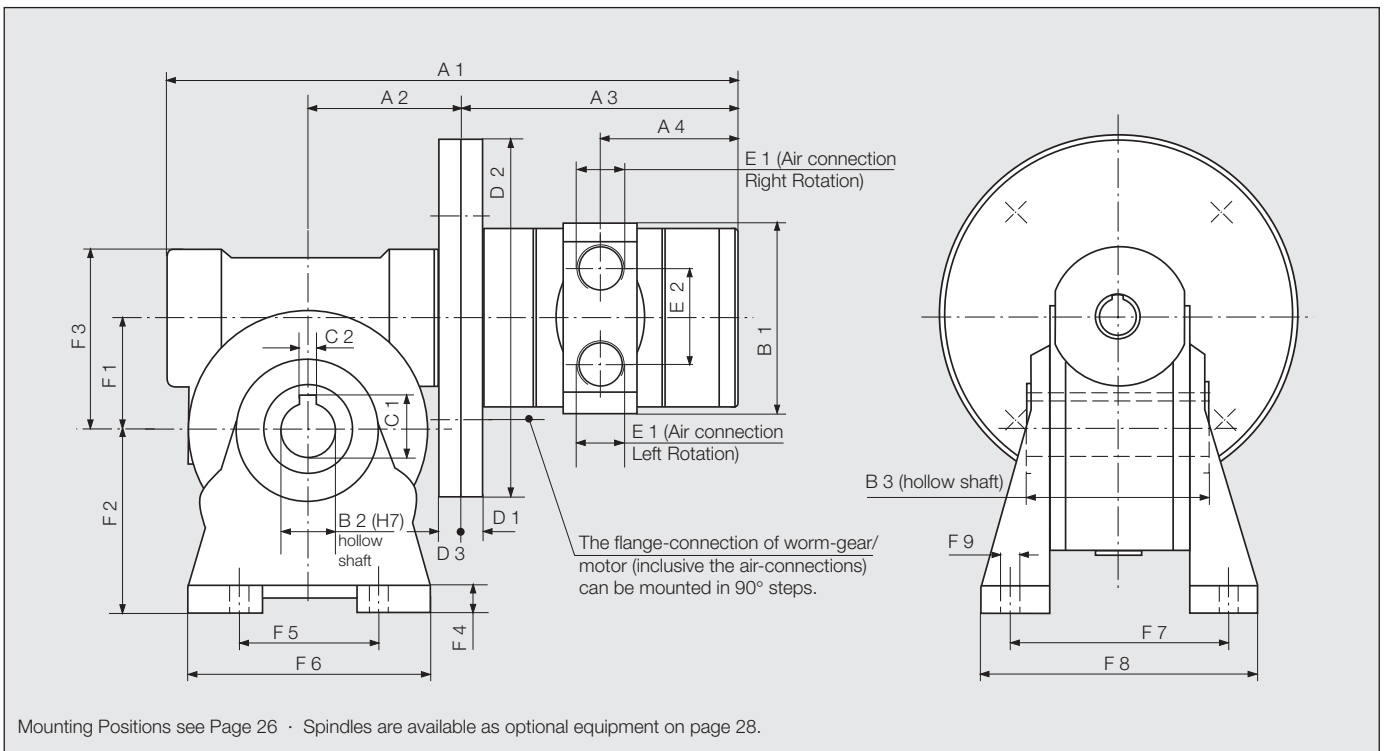

Motor Size 9 with Worm-Gear		Dimensions of Bracket motor (mm)																						
Type		A1	A2	A3	A4	B1	B2	B3	C1	C2	D1	D2	D3	E1	E2	F1	F2	F3	F4	F5	F6	F7	F8	F9
68-W014..		260	70	127	64	85	25	82	28.3	8	10	160	10.5	1/2"	44	49.5	82	80	12	63	110	98.5	124	8.5

# Technical Data

The motors in this design series can be operated in either right- or left rotation. Alternatively, the motor can also be reversed by two external 3/2-way valves or one 5/3-way valve (each with sufficiently large cross-sections).

Motor Size 9 with Worm-Gear		General-purpose housing		
Motor, reversible by external valve	type order no.	68 - W030U - ..-...-09 446225 A - F <sup>1)</sup>	68 - W064U - ..-...-09 446226 A - F <sup>1)</sup>	68 - W080U - ..-...-09 446227 A - F <sup>1)</sup>
Nominal-Power	kW / HP	1.6 / 2.1	1.6 / 2.1	1.6 / 2.1
Nominal-Speed	rpm	150	70	55
Speed (idling)	rpm	200 <sup>2)</sup>	95 <sup>2)</sup>	75 <sup>2)</sup>
Nominal-Torque	Nm / in.lbs	77 / 681	154 / 1363	180 / 1593
Start-Torque min.	Nm / in.lbs	65 / 575	117 / 1035	130 / 1150
For permissible radial and axial forces please check "optional accessories" on page 28				
Air Consumption	m <sup>3</sup> /min / cfm	1.9 / 67	1.9 / 67	1.9 / 67
Weight	kg / lbs	10.5 / 23.1	17.8 / 39.2	17.8 / 39.2
Hose I. D.	mm / in.	15 / <sup>5</sup> / <sub>8</sub>	15 / <sup>5</sup> / <sub>8</sub>	15 / <sup>5</sup> / <sub>8</sub>
Gear type		W63U	W86U	W86U
Max. gear torque for permanent load	Nm / in.lbs	125 / 1106	250 / 2212	250 / 2212

Performance data relate to an air pressure of 6 bar (85 PSI)

<sup>1)</sup> A / B / C / D / E / F = mounting position 0B3 / 0B6 / 0B7 / 0B8 / 0V5 / 0V6  
(Example: mounting position 0B6 = order no. XXXXX C)  
<sup>2)</sup> max. admissible Speed (idling)

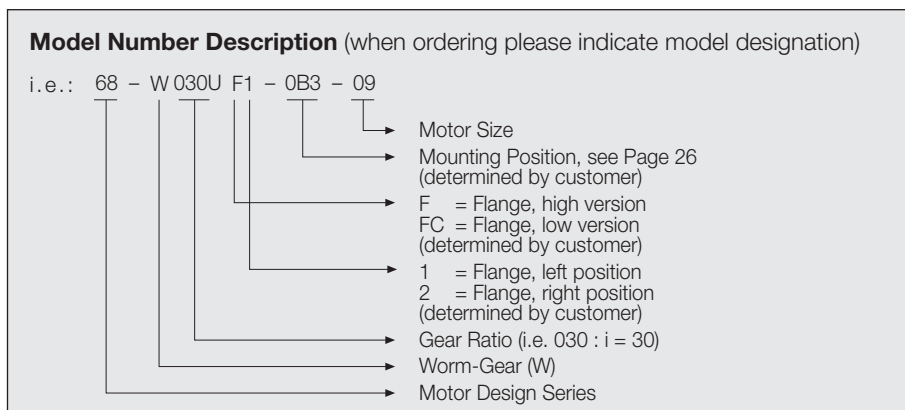

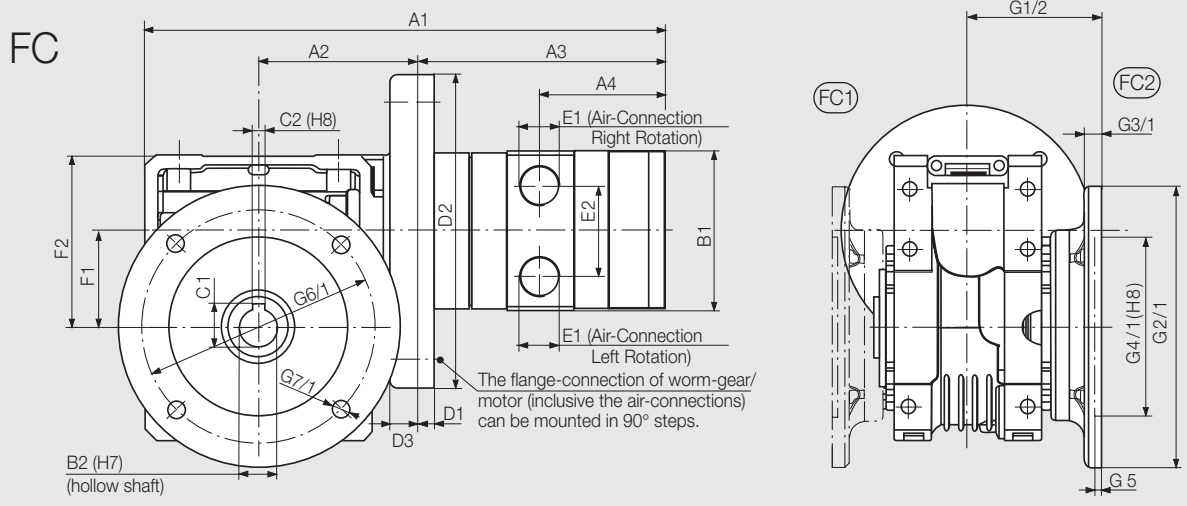
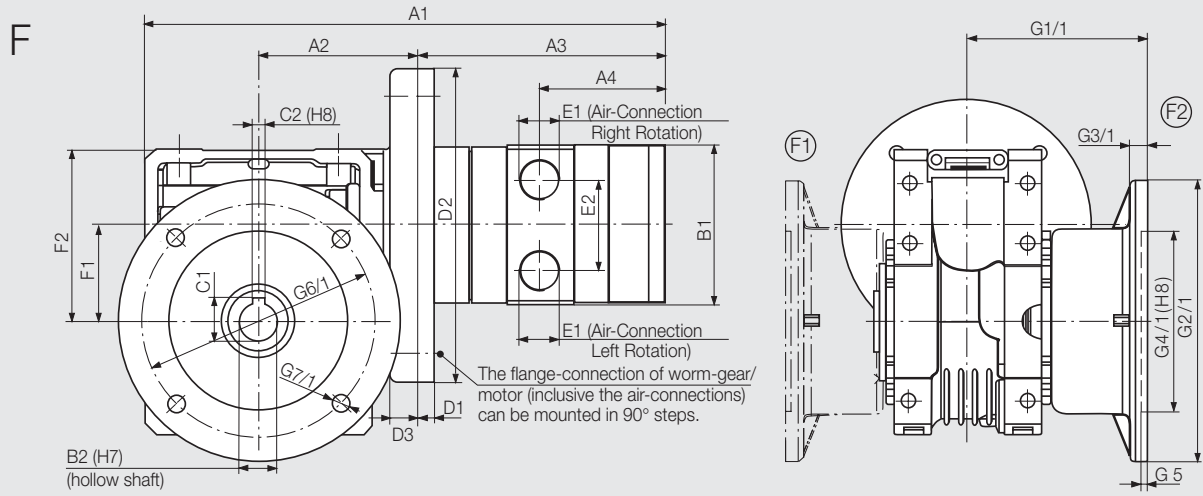
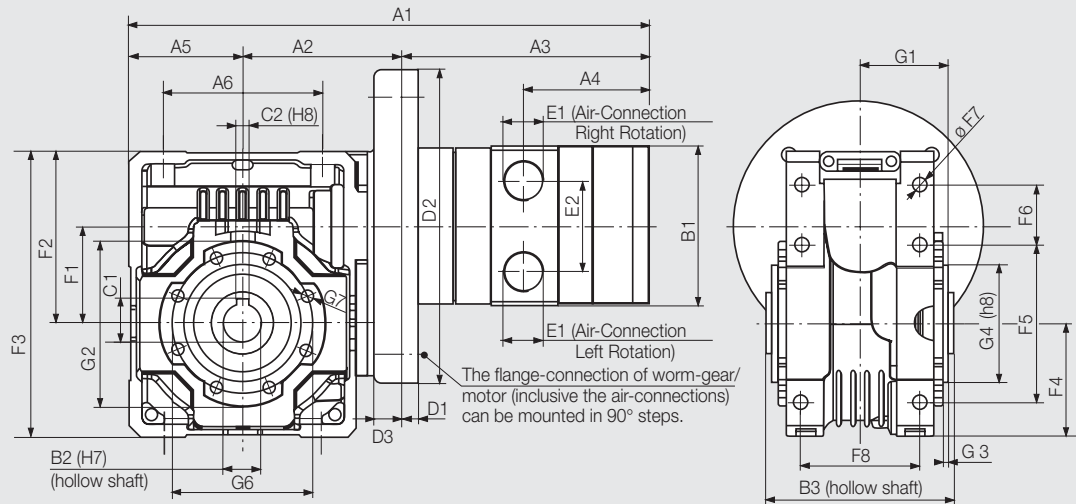

172760

**Motor Size 9 with Worm-Gear**

Type	Dimensions of Flange motor (mm)																			
	A1	A2	A3	A4	A5	A6	B1	B2	B3	C1	C2	D1	D2	D3	E1	E2	F1	F2	F3	F4
68-W030U	294.5	95	127	64	72.5	102	85	25	120	28.3	8	10	160	11	1/2"	44	62.17	110	182.5	72.5
68-W064U	355	128	127	64	100	144	85	35	140	38.3	10	10	160	14	1/2"	44	86.9	145.5	245.5	100
68-W080U																				
	F5	F6	F7	F8	G1	G1/1	G1/2	G2	G2/1	G3	G3/1	G4	G4/1	G5	G6	G6/1	G7			G7/1
68-W030U	102	37.5	9	76	56	116	86	105	180	3	11	75	115	5	90	150	M8x14		11	
68-W064U	144	45.5	11.5	101	68	151	110.5	150	210	3.5	11	110	152	6	130	150	M10x18		11	
68-W080U																				

Flange F and FC are "optional accessories".

# Technical Data

The motors in this design series can be operated in either right- or left rotation. Alternatively, the motor can also be reversed by two external 3/2-way valves or one 5/3-way valve (each with sufficiently large cross-sections).

Motor Size 9 with Spur-Gear		Flange motor					
Motor, reversible by external valve	<b>type</b> order no.	<b>68-S007</b> <b>F- ... -09</b> 444845 A - C <sup>1)</sup>	<b>68-S016</b> <b>F- ... -09</b> 444846 A - C <sup>1)</sup>	<b>68-S036</b> <b>F- ... -09</b> 444847 A - C <sup>1)</sup>	<b>68-S064</b> <b>F- ... -09</b> 446233 A - C <sup>1)</sup>	<b>68-S135</b> <b>F- ... -09</b> 444849 A - C <sup>1)</sup>	<b>68-S238</b> <b>F- ... -09</b> 446241 A - C <sup>1)</sup>
Nominal-Power	kW / HP	1.6 / 2.1	1.6 / 2.1	1.6 / 2.1	1.6 / 2.1	1.6 / 2.1	1.6 / 2.1
Nominal-Speed	rpm	590	280	120	70	33	18
Speed (idling)	rpm	660 <sup>2)</sup>	320 <sup>2)</sup>	140 <sup>2)</sup>	80 <sup>2)</sup>	37 <sup>2)</sup>	21 <sup>2)</sup>
Nominal-Torque	Nm / in.lbs	24 / 212	50 / 442	113 / 1000	197 / 1743	413 / 3655	716 / 6337
Start-Torque	min. Nm / in.lbs	36 / 319	75 / 664	171 / 1513	299 / 2646	626 / 5540	1084 / 9593
Radial force	max. N / lbs	1220 / 273	2030 / 455	4030 / 903	5800 / 1299	10000 / 2220	16000 / 3570
Axial force	max. N / lbs	244 / 55	406 / 91	806 / 181	1160 / 260	2000 / 445	3200 / 710
Air Consumption	m <sup>3</sup> /min / cfm	1.9 / 67	1.9 / 67	1.9 / 67	1.9 / 67	1.9 / 67	1.9 / 67
Weight	kg / lbs	9.8 / 22	11.5 / 25	14.4 / 31.7	31.7 / 69.7	49.2 / 108.2	67.2 / 147.8
Hose I. D.	mm / in.	15 / <sup>5</sup> / <sub>8</sub>	15 / <sup>5</sup> / <sub>8</sub>	15 / <sup>5</sup> / <sub>8</sub>	15 / <sup>5</sup> / <sub>8</sub>	15 / <sup>5</sup> / <sub>8</sub>	15 / <sup>5</sup> / <sub>8</sub>
Gear type		S112F	S212F	S312F	S413F	S513F	S614F
Max. gear torque for permanent load	Nm / in.lbs	45 / 398	140 / 1239	280 / 2478	560 / 4956	1000 / 8850	1600 / 14160

Performance data relate to an air pressure of 6 bar (85 PSI)

<sup>1)</sup> A / B / C = mounting position 0B5 / 0V1 / 0V3  
(Example: mounting position 0V1 = order no. XXXXXX B)  
<sup>2)</sup> max. admissible Speed (idling)

Motor Size 9 with Spur-Gear		Bracket motor					
Motor, reversible by external valve	<b>type</b> order no.	<b>68-S007</b> <b>K- ... -09</b> 444851 A - F <sup>1)</sup>	<b>68-S016</b> <b>K- ... -09</b> 444852 A - F <sup>1)</sup>	<b>68-S036</b> <b>K- ... -09</b> 444853 A - F <sup>1)</sup>	<b>68-S064</b> <b>K- ... -09</b> 446234 A - F <sup>1)</sup>	<b>68-S135</b> <b>K- ... -09</b> 444855 A - F <sup>1)</sup>	<b>68-S238</b> <b>K- ... -09</b> 446242 A - F <sup>1)</sup>
Nominal-Power	kW / HP	1.6 / 2.1	1.6 / 2.1	1.6 / 2.1	1.6 / 2.1	1.6 / 2.1	1.6 / 2.1
Nominal-Speed	rpm	590	280	120	70	33	20
Speed (idling)	rpm	660 <sup>2)</sup>	320 <sup>2)</sup>	140 <sup>2)</sup>	80 <sup>2)</sup>	37 <sup>2)</sup>	25 <sup>2)</sup>
Nominal-Torque	Nm / in.lbs	24 / 212	50 / 442	113 / 1000	197 / 1743	413 / 3655	716 / 6337
Start-Torque	min. Nm / in.lbs	36 / 319	75 / 664	171 / 1513	299 / 2646	626 / 5540	1084 / 9593
Radial force	max. N / lbs	1220 / 273	2030 / 455	4030 / 903	5800 / 1299	10000 / 2220	16000 / 3570
Axial force	max. N / lbs	244 / 55	406 / 91	806 / 181	1160 / 260	2000 / 445	3200 / 710
Air Consumption	m <sup>3</sup> /min / cfm	1.9 / 67	1.9 / 67	1.9 / 67	1.9 / 67	1.9 / 67	1.9 / 67
Weight	kg / lbs	9.8 / 22	11.5 / 25	14.4 / 31.7	31.7 / 69.7	49.2 / 108.2	67.2 / 147.8
Hose I. D.	mm / in.	15 / <sup>5</sup> / <sub>8</sub>	15 / <sup>5</sup> / <sub>8</sub>	15 / <sup>5</sup> / <sub>8</sub>	15 / <sup>5</sup> / <sub>8</sub>	15 / <sup>5</sup> / <sub>8</sub>	15 / <sup>5</sup> / <sub>8</sub>
Gear type		S112K	S212K	S312K	S413K	S513K	S614K
Max. gear torque for permanent load	Nm / in.lbs	45 / 398	140 / 1239	280 / 2478	560 / 4956	1000 / 8850	1600 / 14160

Performance data relate to an air pressure of 6 bar (85 PSI)

<sup>1)</sup> A / B / C / D / E / F = mounting position 0B3 / 0B6 / 0B7 / 0B8 / 0V5 / 0V6  
(Example: mounting position 0B7 = order no. XXXXXX C)  
<sup>2)</sup> max. admissible Speed (idling)

## Model Number Description (when ordering please indicate model designation)

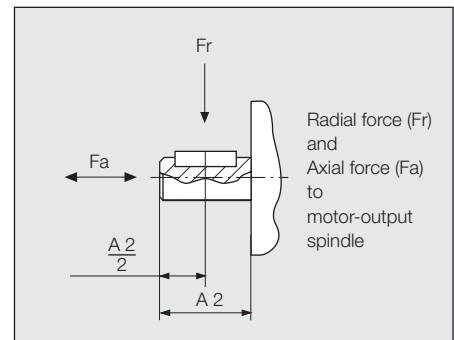
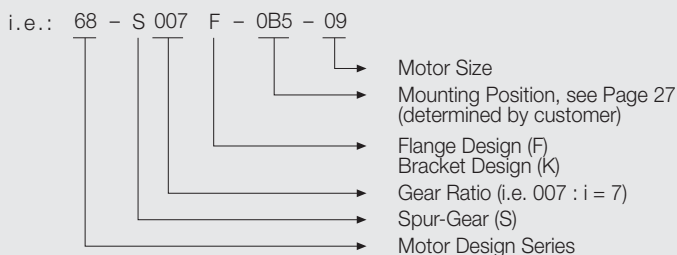

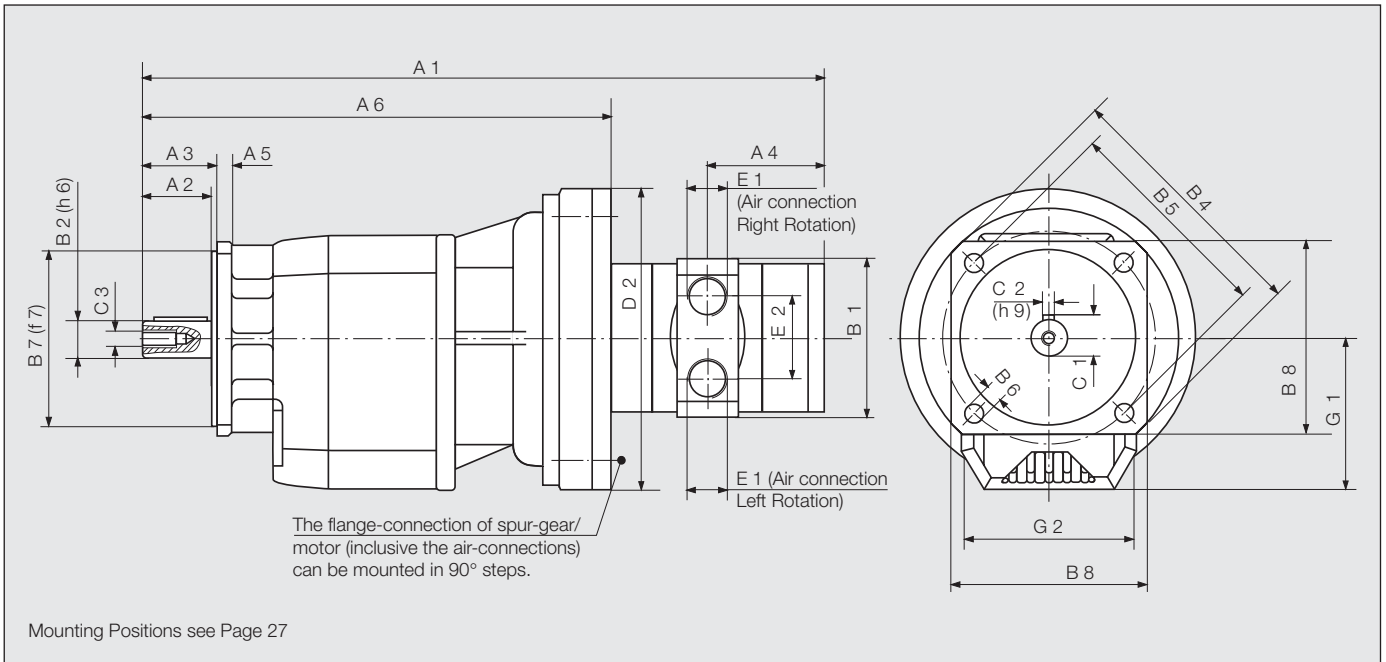

**Motor Size 9 with Spur-Gear**

Type	Dimensions of Flange motor (mm)																				
	A1	A2	A3	A4	A5	A6	B1	B2	B4	B5	B6	B7	B8	C1	C2	C3	D2	E1	E2	G1	G2
68-S007..	371	37	40	64	8	254	85	20	140	115	9.5	95	105	22.5	6	M8	160	1/2"	44	82	95
68-S016..	400	46.5	50	64	10	283	85	25	160	130	9.5	110	135	28	8	M8	160	1/2"	44	92	110
68-S036..	434	56.5	60	64	12	317	85	30	200	165	11.5	130	150	33	8	M10	160	1/2"	44	108	130
68-S064..	464	66	70	64	13	347	85	35	250	215	14	180	210	38	10	M10	160	1/2"	44	128	155
68-S135..	489	76	80	64	16	372	85	40	300	265	14	230	260	43	12	M12	160	1/2"	44	152	185
68-S238..	544	95	100	64	18	427	85	50	350	300	18	250	260	53.5	14	M16	160	1/2"	44	178.5	210

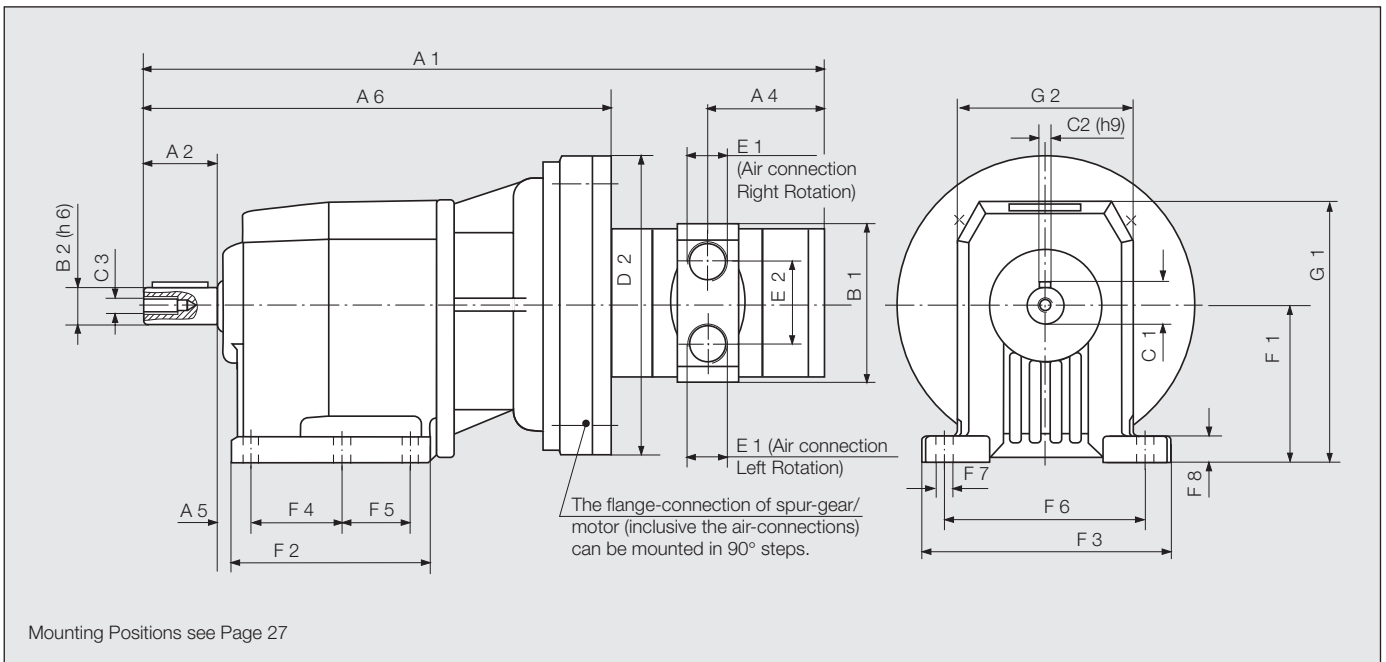

**Motor Size 9 with Spur-Gear**

Type	Dimensions of Bracket motor (mm)																						
	A1	A2	A4	A5	A6	B1	B2	C1	C2	C3	D2	E1	E2	F1	F2	F3	F4	F5	F6	F7	F8	G1	G2
68-S007..	371	40	64	18	254	85	20	22.5	6	M8	160	1/2"	44	85	107	130	50	37	110	9	15	141	95
68-S016..	400	50	64	18	283	85	25	28	8	M8	160	1/2"	44	100	137	155	60	47.5	130	11	17	166	110
68-S036..	434	60	64	18	317	85	30	33	8	M10	160	1/2"	44	110	156	190	70	60	160	11	20	181	130
68-S064..	464	70	64	20	347	85	35	38	10	M10	160	1/2"	44	130	185.5	216	149.5	-	180	14	18	221	155
68-S135..	498	80	64	25	372	85	40	43	12	M12	160	1/2"	44	155	200	270	156	-	225	18	22	278	185
68-S238..	614	100	64	25	497	85	50	53.5	14	M16	160	1/2"	44	195	232	300	180	-	250	18	25	316	210

## Technical Data

The motors in this design series can be operated in either right- or left rotation.

Alternatively, the motor can also be reversed by two external 3/2-way valves or one 5/3-way valve (each with sufficiently large cross-sections).

<b>Motor Size 11</b> without Gearing		<b>Flange motor</b>	
Motor, reversible by external valve	<b>type</b> oder no.	<b>68-0011/ IEC 80 A</b> 444777 A	
Nominal-Power	kW / HP	2.6 / 3.5	
Nominal-Speed	rpm	3500	
Speed (idling)	rpm	7000	
Nominal-Torque	Nm / in.lbs	7.1 / 63	
Start-Torque min.	Nm / in.lbs	11 / 97	
Radial force max.	N / lbs	1400 / 300	
Axial force max.	N / lbs	700 / 150	
Air Consumption	m <sup>3</sup> /min / cfm	3.6 / 127	
Weight	kg / lbs	7.9 / 17	
Hose I. D.	mm / in.	19 / 3/4	

Performance data relate to an air pressure of 6 bar (85 PSI)

<b>Motor Size 11</b> with Planetary-Gear		<b>Flange motor</b>		
Motor, reversible by external valve	<b>type</b> order no.	<b>68 - P005F - 000 - 11</b> 444857 A	<b>68 - P010F - 000 - 11</b> 444857 B	<b>68 - P025F - 000 - 11</b> 444857 C
Nominal-Power	kW / HP	2.6 / 3.5	2.6 / 3.5	2.6 / 3.5
Nominal-Speed	rpm	700	350	140
Speed (idling)	rpm	1200 *)	600 *)	190 *)
Nominal-Torque	Nm / in.lbs	34 / 301	40 <sup>1)</sup> / 354	100 <sup>1)</sup> / 885
Start-Torque min.	Nm / in.lbs	51 / 451	40 <sup>1)</sup> / 354	100 <sup>1)</sup> / 885
Radial force max.	N / lbs	2400 / 530	2400 / 530	4600 / 1020
Axial force max.	N / lbs	1900 / 420	1900 / 420	4000 / 890
Air Consumption	m <sup>3</sup> /min / cfm	3.6 / 127	3.6 / 127	3.6 / 127
Weight	kg / lbs	12 / 26	12 / 26	19.1 / 42
Hose I. D.	mm / in.	19 / 3/4	19 / 3/4	19 / 3/4
Gear type		P90F	P90F	P120F
Max. gear torque for permanent load	Nm / in.lbs	40 / 354	40 <sup>1)</sup> / 354	100 <sup>1)</sup> / 885

Performance data relate to an air pressure of 6 bar (85 PSI)

\*) max. admissible Speed (idling)

<sup>1)</sup> Maximum torque 480 Nm for a maximum of 1000 cycles under load.

### Model Number Description

i.e.: 68 - P 005 F - 000 - 11

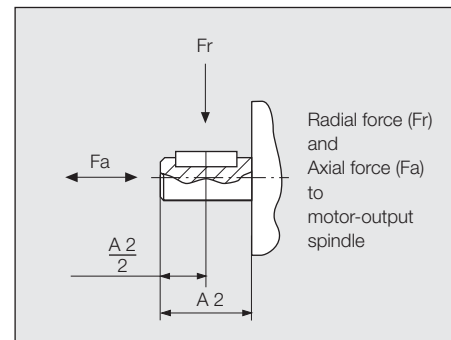
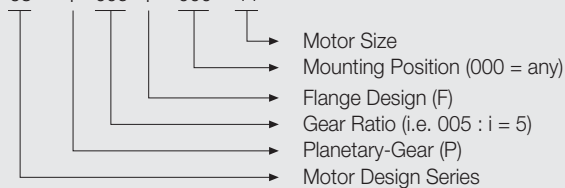

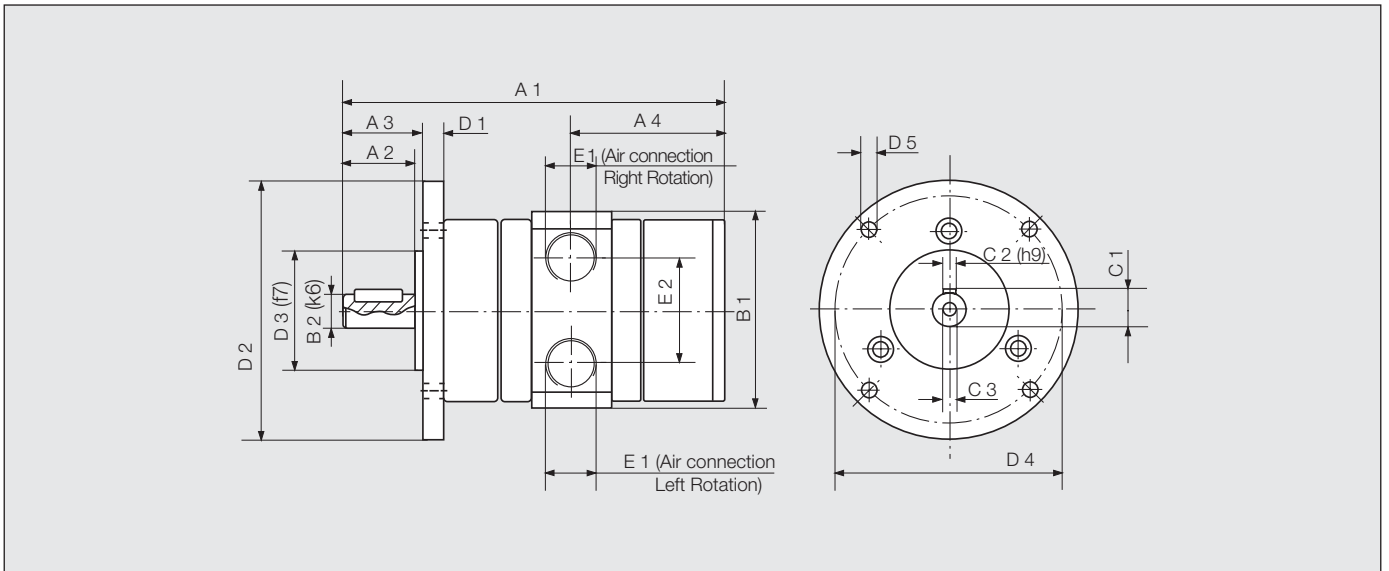

Motor Size 11 without Gearing																
Type	Dimensions of Flange motor (mm)															
	A1	A2	A3	A4	B1	B2	C1	C2	C3	D1	D2	D3	D4	D5	E1	E2
68-0011 / IEC 80 A	199	36.5	40	81	102	19	21.5	6	M8	11	200	130	165	11	3/4"	58

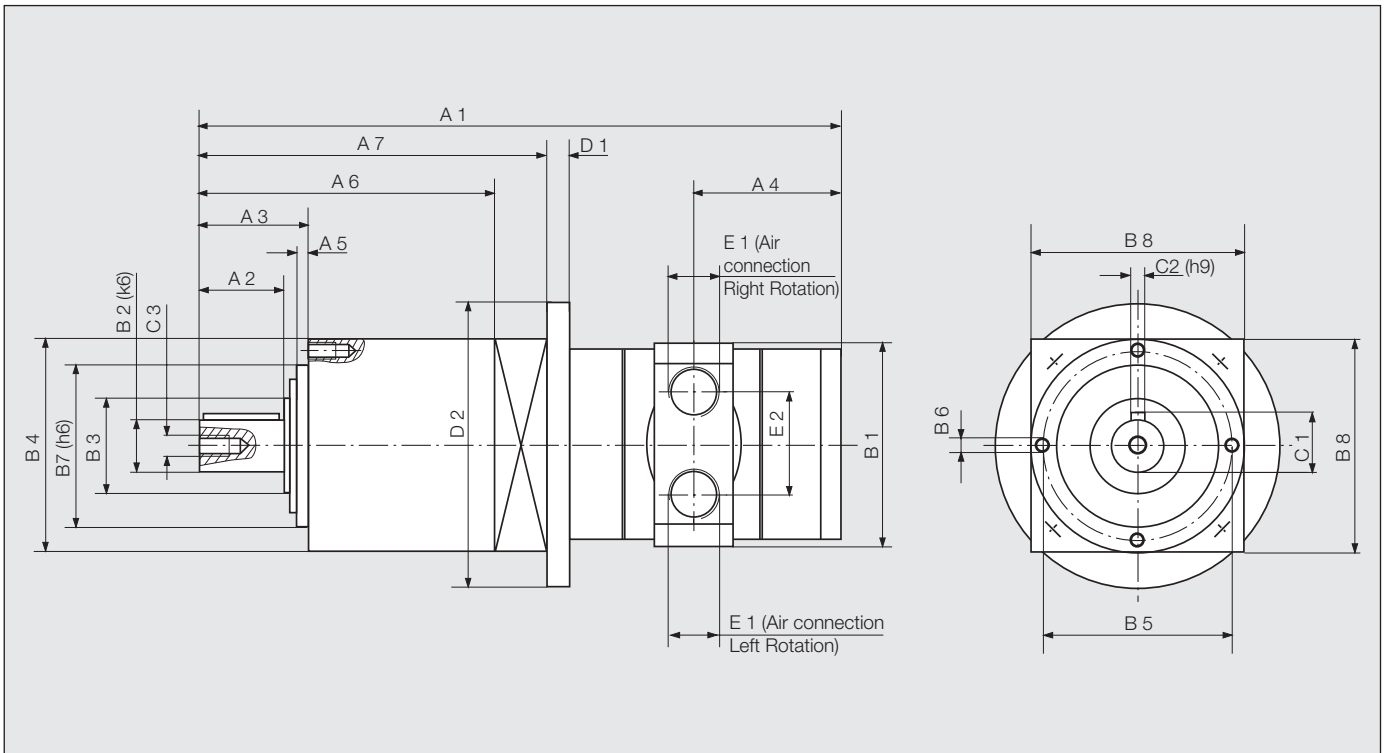

Motor Size 11 with Planetary-Gear													
Type	Dimensions of Flange motor (mm)												
	A1	A2	A3	A4	A5	A6	A7	B1	B2	B3	B4	B5	B6
68-P005F-000-11	68-P010F-000-11	317	36	46	81	5	126	158	102	22	40	90	
68-P025F-000-11		392	58	70	81	6	205	233	102	32	50	120	

Motor Size 11 with Planetary-Gear													
Type	Dimensions of Flange motor (mm)												
	B5	B6	B7	B8	C1	C2	C3	D1	D2	E1	E2	B5	B6
68-P005F-000-11	68-P010F-000-11	80	M6	68	140	24.5	6	M8	11	200	3/4"	58	
68-P025F-000-11		108	M8	90	140	35	10	M12	11	200	3/4"	58	

## Technical Data

The motors in this design series can be operated in either right- or left rotation. Alternatively, the motor can also be reversed by two external 3/2-way valves or one 5/3-way valve (each with sufficiently large cross-sections).

<b>Motor Size 11</b> with Worm-Gear		<b>Flange motor</b>	<b>Bracket motor</b>
Motor, reversible by external valve	<b>type</b>  order no.	<b>68-W080</b> <b>F1- . . . -11</b> 444886 A - F <sup>1)</sup>	<b>68-W080</b> <b>KA- . . . -11</b> 444890 A - F <sup>1)</sup>
Nominal-Power	kW / HP	2.6 / 3.5	2.6 / 3.5
Nominal-Speed	rpm	44	44
Speed (idling)	rpm	62 <sup>2)</sup>	62 <sup>2)</sup>
Nominal-Torque	Nm / in.lbs	415 / 3673	415 / 3673
Start-Torque min.	Nm / in.lbs	308 / 2726	308 / 2726
For permissible radial and axial forces please check "optional accessories" on page 28			
Air Consumption	m <sup>3</sup> /min / cfm	3.6 / 127	3.6 / 127
Weight	kg / lbs	57 / 125	57 / 125
Hose I. D.	mm / in.	19 / 3/4	19 / 3/4
Gear type		W130F	W130K
Max. gear torque for permanent load	Nm / in.lbs	660 / 5841	660 / 5841

Performance data relate to an air pressure of 6 bar (85 PSI)

<sup>1)</sup> A / B / C / D / E / F = mounting position 0B3 / 0B6 / 0B7 / 0B8 / 0V5 / 0V6  
(Example: mounting position 0B6 = order no. XXXXXX B)  
<sup>2)</sup> max. admissible Speed (idling)

### Model Number Description (when ordering please indicate model designation)

i.e.: 68 - W 080 F1 - 0B3 - 11

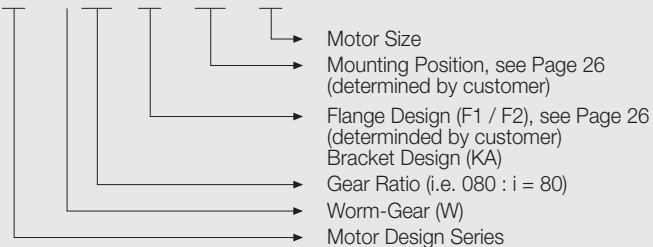

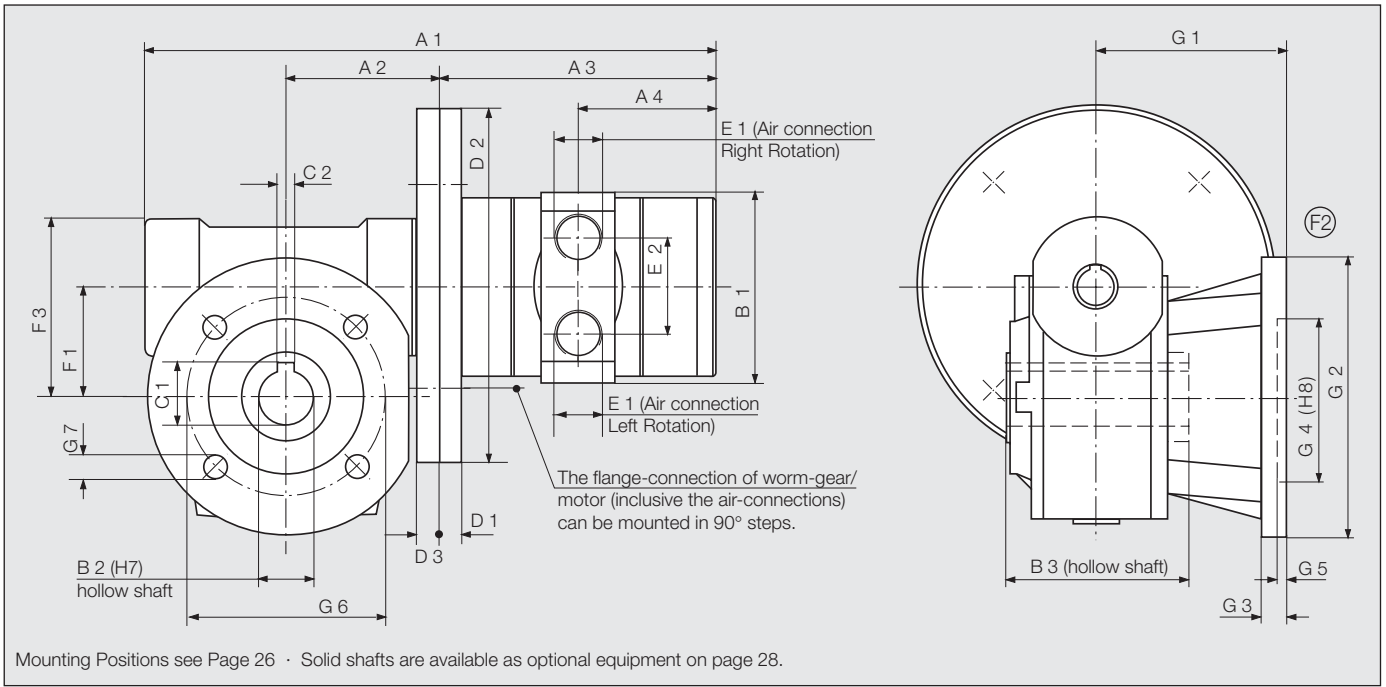

**Motor Size 11 with Worm Gear**

Type	Dimensions of Flange motor (mm)																						
	A1	A2	A3	A4	B1	B2	B3	C1	C2	D1	D2	D3	E1	E2	F1	F3	G1	G2	G3	G4	G5	G6	G7
68-W080..	498	185	159	81	102	45	165	48.8	14	11	200	12	3/4"	58	130	195	197.5	320	20	180	18	255	16 (8x)

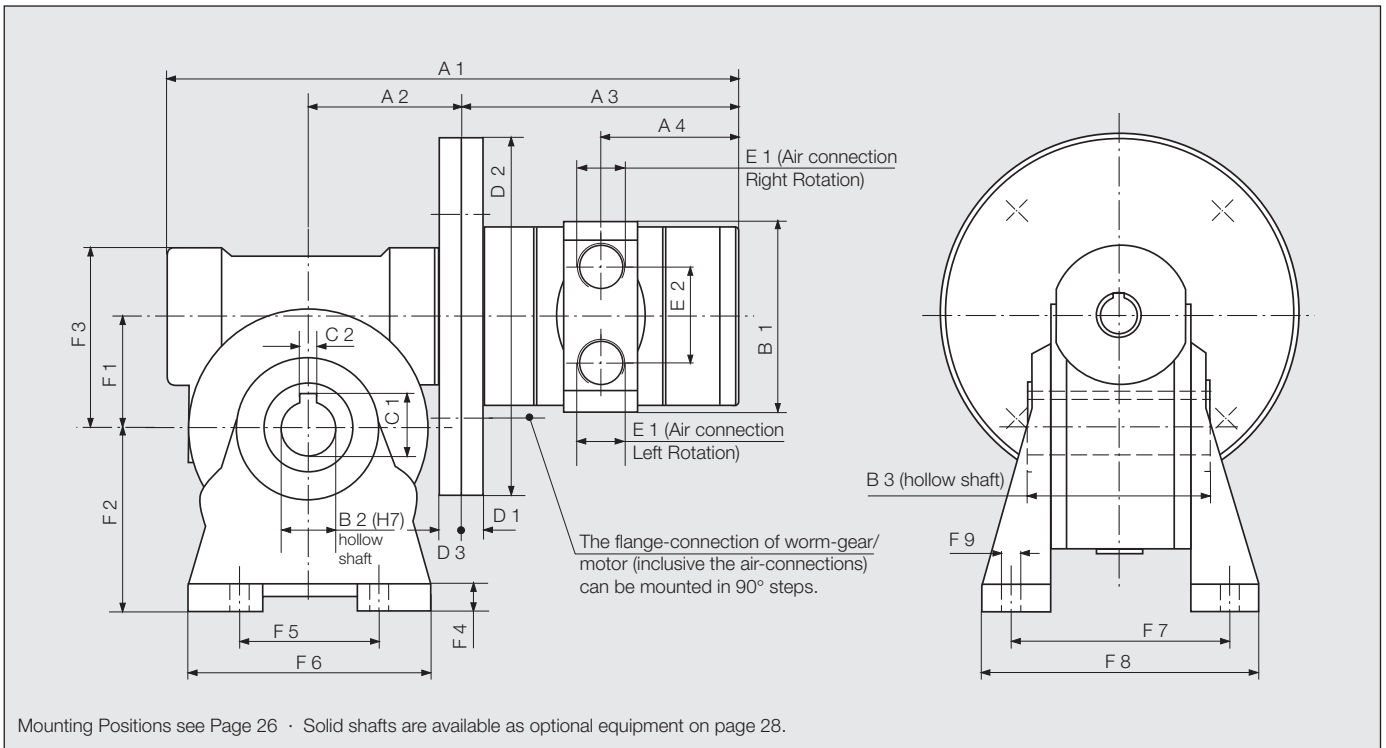

**Motor Size 11 with Worm-Gear**

Type	Dimensions of Bracket motor (mm)																						
	A1	A2	A3	A4	B1	B2	B3	C1	C2	D1	D2	D3	E1	E2	F1	F2	F3	F4	F5	F6	F7	F8	F9
68-W080..	498	185	159	81	102	45	165	48.8	14	11	200	12	3/4"	58	130	195	195	18	220	310	191	245	16

## Technical Data

The motors in this design series can be operated in either right- or left rotation. Alternatively, the motor can also be reversed by two external 3/2-way valves or one 5/3-way valve (each with sufficiently large cross-sections).

Motor Size 11 with Worm-Gear		General-purpose housing		
Motor, reversible by external valve	<b>type</b>  order no.	<b>68-W010 U</b> <b>...-...-11</b> 446243 A - F <sup>1)</sup>	<b>68-W024U</b> <b>...-...-11</b> 446228 A - F <sup>1)</sup>	<b>68-W040U</b> <b>...-...-11</b> 446229 A - F <sup>1)</sup>
Nominal-Power	kW / HP	2.6 / 3.5	2.6 / 3.5	2.6 / 3.5
Nominal-Speed	rpm	350	150	85
Speed (idling)	rpm	500 <sup>2)</sup>	220 <sup>2)</sup>	125 <sup>2)</sup>
Nominal-Torque	Nm / in.lbs	62 / 549	133 / 1177	224 / 1982
Start-Torque min.	Nm / in.lbs	71 / 628	133 / 1177	191 / 1690
For permissible radial and axial forces please check "optional accessories" on page 28				
Air Consumption	m <sup>3</sup> /min / cfm	3.6 / 127	3.6 / 127	3.6 / 127
Weight	kg / lbs	14.5 / 32	21 / 46	21 / 46
Hose I. D.	mm / in.	19 / <sup>3</sup> / <sub>4</sub>	19 / <sup>3</sup> / <sub>4</sub>	19 / <sup>3</sup> / <sub>4</sub>
Gear type		W63U	W86U	W86U
Max. gear torque for permanent load	Nm / in.lbs	125 / 1106	285 / 2522	295 / 2611

Performance data relate to an air pressure of 6 bar (85 PSI)

<sup>1)</sup> A / B / C / D / E / F = mounting position 0B3 / 0B6 / 0B7 / 0B8 / 0V5 / 0V6  
(Example: mounting position 0B6 = order no. XXXXXX B)  
<sup>2)</sup> max. admissible Speed (idling)

### Model Number Description (when ordering please indicate model designation)

i.e.: 68 - W010U F1 - 0B3 - 11

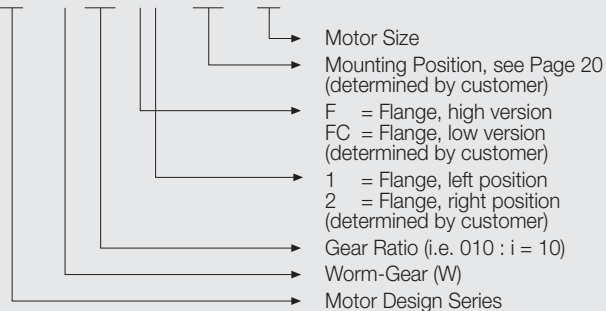

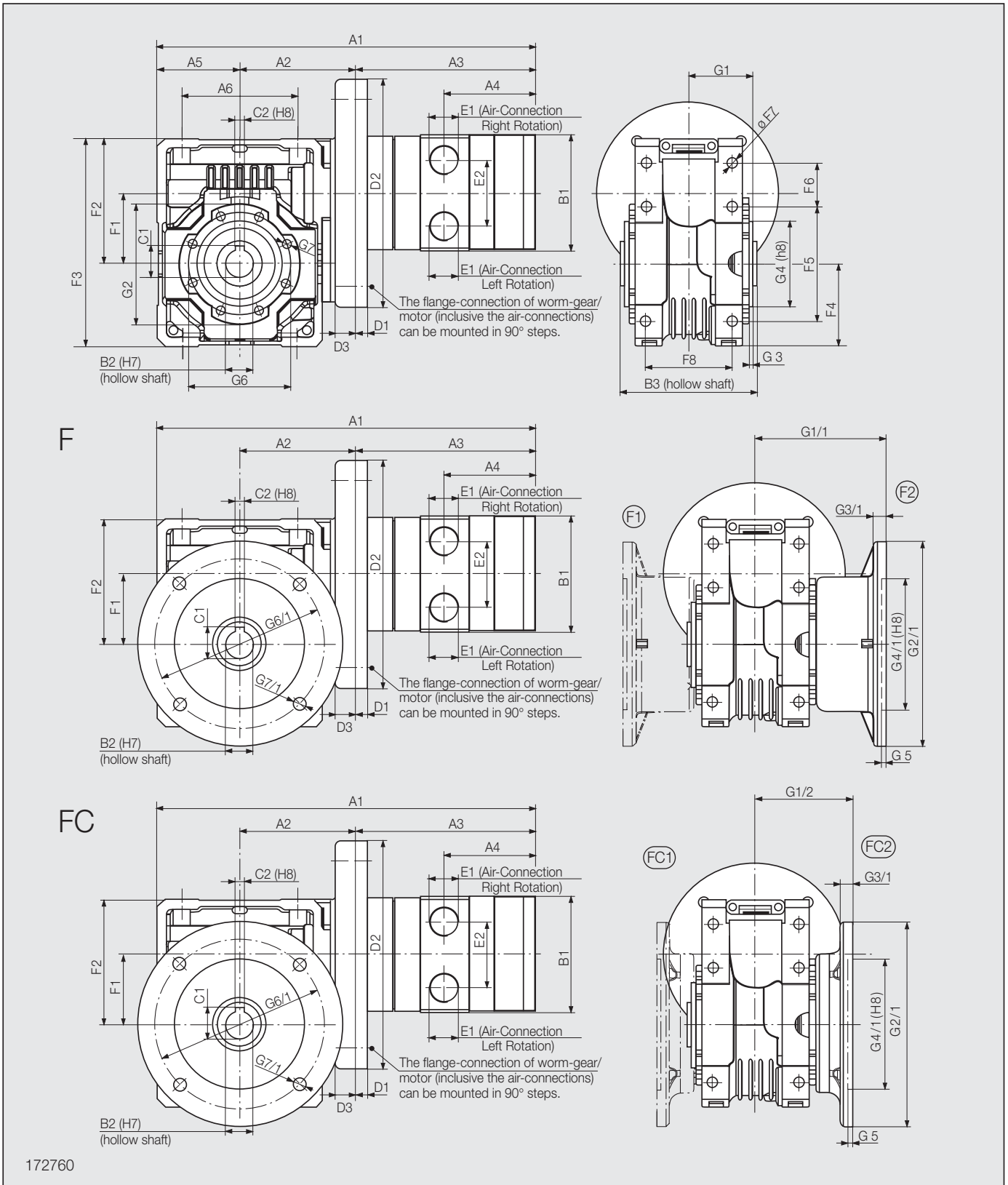

172760

Motor Size 11 with Worm-Gear																				
Type	Dimensions of Flange motor (mm)																			
	A1	A2	A3	A4	A5	A6	B1	B2	B3	C1	C2	D1	D2	D3	E1	E2	F1	F2	F3	F4
68-W010U	333.5	102	159	81	72.5	102	102	25	120	28.3	8	11	200	12	3/4"	58	62.2	110	182.5	72.5
68-W024U	387	128	159	81	100	144	102	35	140	38.3	10	11	200	12	3/4"	58	86.9	145.5	245.5	100
68-W040U		F5	F6	F7	F8	G1	G1/1	G1/2	G2	G2/1	G3	G3/1	G4	G4/1	G5	G6	G6/1	G7		G7/1
68-W010U	102	37.5	9	76	53	116	86	105	180	3	11	75	115	5	90	150	M8x14		11	
68-W024U	144	45.5	11.5	101	68	151	110.5	150	210	3.5	15	110	152	6	130	176	M10x18		12.5	
68-W040U																				

Flange F and FC are "optional accessories".

# Technical Data

The motors in this design series can be operated in either right- or left rotation. Alternatively, the motor can also be reversed by two external 3/2-way valves or one 5/3-way valve (each with sufficiently large cross-sections).

Motor Size 11 with Spur-Gear		Flange motor					
Motor, reversible by external valve	<b>type</b> order no.	<b>68-S006</b> <b>F- ... -11</b> 444871 A - C <sup>1)</sup>	<b>68-S010</b> <b>F- ... -11</b> 444872 A - C <sup>1)</sup>	<b>68-S020</b> <b>F- ... -11</b> 444873 A - C <sup>1)</sup>	<b>68-S045</b> <b>F- ... -11</b> 444874 A - C <sup>1)</sup>	<b>68-S093</b> <b>F- ... -11</b> 446244 A - C <sup>1)</sup>	<b>68-S150</b> <b>F- ... -11</b> 446245 A - C <sup>1)</sup>
Nominal-Power	kW / HP	2.6 / 3.5	2.6 / 3.5	2.6 / 3.5	2.6 / 3.5	2.6 / 3.5	2.6 / 3.5
Nominal-Speed	rpm	565	365	175	80	40	20
Speed (idling)	rpm	800 <sup>2)</sup>	520 <sup>2)</sup>	250 <sup>2)</sup>	110 <sup>2)</sup>	55 <sup>2)</sup>	30 <sup>2)</sup>
Nominal-Torque	Nm / in.lbs	42 / 370	65 / 575	135 / 1195	302 / 2672	614 / 5434	990 / 8761
Start-Torque	min. Nm / in.lbs	64 / 566	100 / 885	210 / 1858	468 / 4142	951 / 8416	1530 / 13540
Radial force	max. N / lbs	660 / 148	1750 / 392	3290 / 737	5130 / 1149	10000 / 2220	16000 / 3570
Axial force	max. N / lbs	132 / 30	350 / 78	658 / 147	1026 / 230	2000 / 445	3200 / 710
Air Consumption	m <sup>3</sup> /min / cfm	3.6 / 127	3.6 / 127	3.6 / 127	3.6 / 127	3.6 / 127	3.6 / 127
Weight	kg / lbs	14.9 / 32.8	16.1 / 35.4	19 / 41.8	36.4 / 80	54.9 / 120.8	68.9 / 151.6
Hose I. D.	mm / in.	19 / <sup>3</sup> / <sub>4</sub>	19 / <sup>3</sup> / <sub>4</sub>	19 / <sup>3</sup> / <sub>4</sub>	19 / <sup>3</sup> / <sub>4</sub>	19 / <sup>3</sup> / <sub>4</sub>	19 / <sup>3</sup> / <sub>4</sub>
Gear type		S112F	S212F	S312F	S412F	S513F	S613F
Max. gear torque for permanent load	Nm / in.lbs	42 / 372	115 / 1018	235 / 2080	500 / 4425	1000 / 8850	1600 / 14160

Performance data relate to an air pressure of 6 bar (85 PSI)

<sup>1)</sup> A / B / C = mounting position 0B5 / 0V1 / 0V3  
(Example: mounting position 0V1 = order no. XXXXXX B)  
<sup>2)</sup> max. admissible Speed (idling)

Motor Size 11 with Spur-Gear		Bracket motor					
Motor, reversible by external valve	<b>type</b> order-no.	<b>68-S006</b> <b>K- ... -11</b> 444877 A - F <sup>1)</sup>	<b>68-S010</b> <b>K- ... -11</b> 444878 A - F <sup>1)</sup>	<b>68-S020</b> <b>K- ... -11</b> 444879 A - F <sup>1)</sup>	<b>68-S045</b> <b>K- ... -11</b> 444880 A - F <sup>1)</sup>	<b>68-S093</b> <b>K- ... -11</b> 446246 A - F <sup>1)</sup>	<b>68-S150</b> <b>K- ... -11</b> 446247 A - F <sup>1)</sup>
Nominal-Power	kW / HP	2.6 / 3.5	2.6 / 3.5	2.6 / 3.5	2.6 / 3.5	2.6 / 3.5	2.6 / 3.5
Nominal-Speed	rpm	565	365	175	80	40	20
Speed (idling)	rpm	800 <sup>2)</sup>	520 <sup>2)</sup>	250 <sup>2)</sup>	110 <sup>2)</sup>	55 <sup>2)</sup>	30 <sup>2)</sup>
Nominal-Torque	Nm / in.lbs	42 / 370	65 / 575	135 / 1195	302 / 2672	614 / 5434	990 / 8761
Start-Torque	min. Nm / in.lbs	64 / 566	100 / 885	210 / 1858	468 / 4142	951 / 8416	1530 / 13540
Radial force	max. N / lbs	660 / 148	1750 / 392	3290 / 737	5130 / 1149	10000 / 2220	16000 / 3570
Axial force	max. N / lbs	132 / 30	350 / 78	658 / 147	1026 / 230	2000 / 445	3200 / 710
Air Consumption	m <sup>3</sup> /min / cfm	3.6 / 127	3.6 / 127	3.6 / 127	3.6 / 127	3.6 / 127	3.6 / 127
Weight	kg / lbs	14.9 / 32.8	16.1 / 35.4	19 / 41.8	36.4 / 80	54.9 / 120.8	68.9 / 151.6
Hose I. D.	mm / in.	19 / <sup>3</sup> / <sub>4</sub>	19 / <sup>3</sup> / <sub>4</sub>	19 / <sup>3</sup> / <sub>4</sub>	19 / <sup>3</sup> / <sub>4</sub>	19 / <sup>3</sup> / <sub>4</sub>	19 / <sup>3</sup> / <sub>4</sub>
Gear type		S112K	S212K	S312K	S412K	S513K	S613K
Max. gear torque for permanent load	Nm / in.lbs	42 / 372	115 / 1018	235 / 2080	500 / 4425	1000 / 8850	1600 / 14160

Performance data relate to an air pressure of 6 bar (85 PSI)

<sup>1)</sup> A / B / C / D / E / F = mounting position 0B3 / 0B6 / 0B7 / 0B8 / 0V5 / 0V6  
(Example: mounting position 0B7 = order no. XXXXXX C)  
<sup>2)</sup> max. admissible Speed (idling)

## Model Number Description (when ordering please indicate model designation)

i.e.: 68 - S 006 F - 0B5 - 11

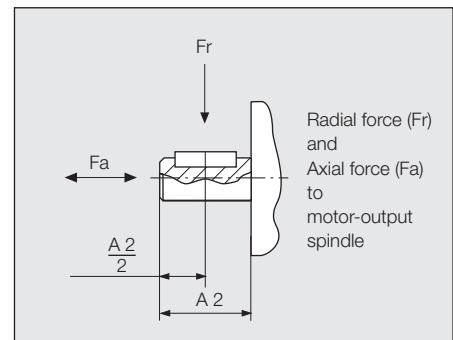
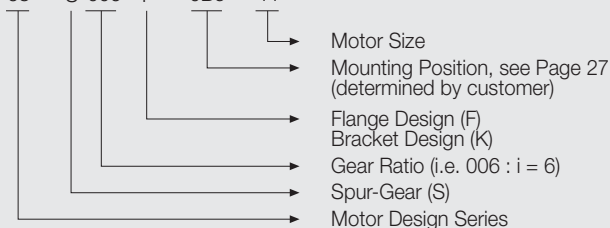

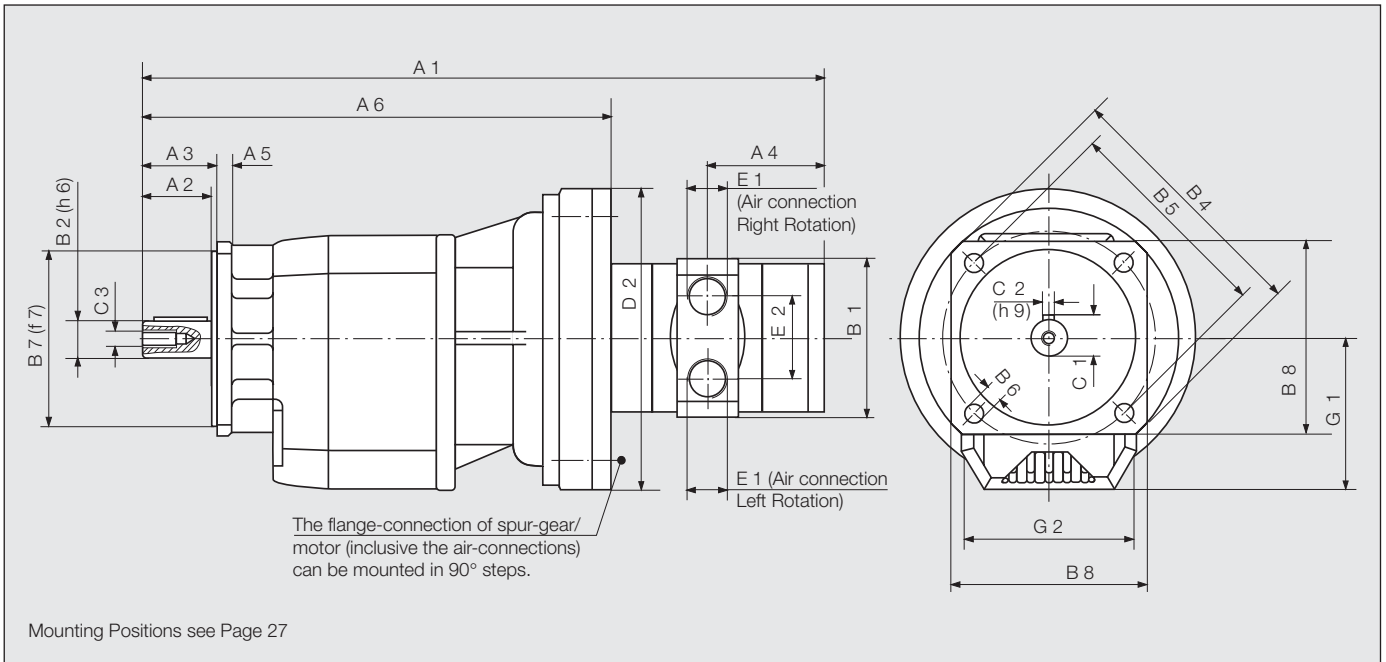

**Motor Size 11 with Spur-Gear**

Type	Dimensions of Flange motor (mm)																					
	A1	A2	A3	A4	A5	A6	B1	B2	B4	B5	B6	B7	B8	C1	C2	C3	D2	E1	E2	G1	G2	
68-S006..	423	37	40	81	8	275	102	20	140	115	9.5	95	105	22.5	6	M8	200	3/4"	58	82	95	
68-S010..	451	46.5	50	81	10	303	102	25	160	130	9.5	110	135	28	8	M8	200	3/4"	58	92	110	
68-S020..	485.5	56.5	60	81	12	337.5	102	30	200	165	11.5	130	150	33	8	M10	200	3/4"	58	108	130	
68-S045..	515.5	66	70	81	13	367.5	102	35	250	215	14	180	-	38	10	M10	200	3/4"	58	128	155	
68-S093..	541	76	80	81	16	393	102	40	300	265	14	230	-	43	12	M12	200	3/4"	58	152	185	
68-S150..	596	96	100	81	16	448	102	50	300	265	14	230	-	53.5	14	M16	200	3/4"	58	178.5	210	

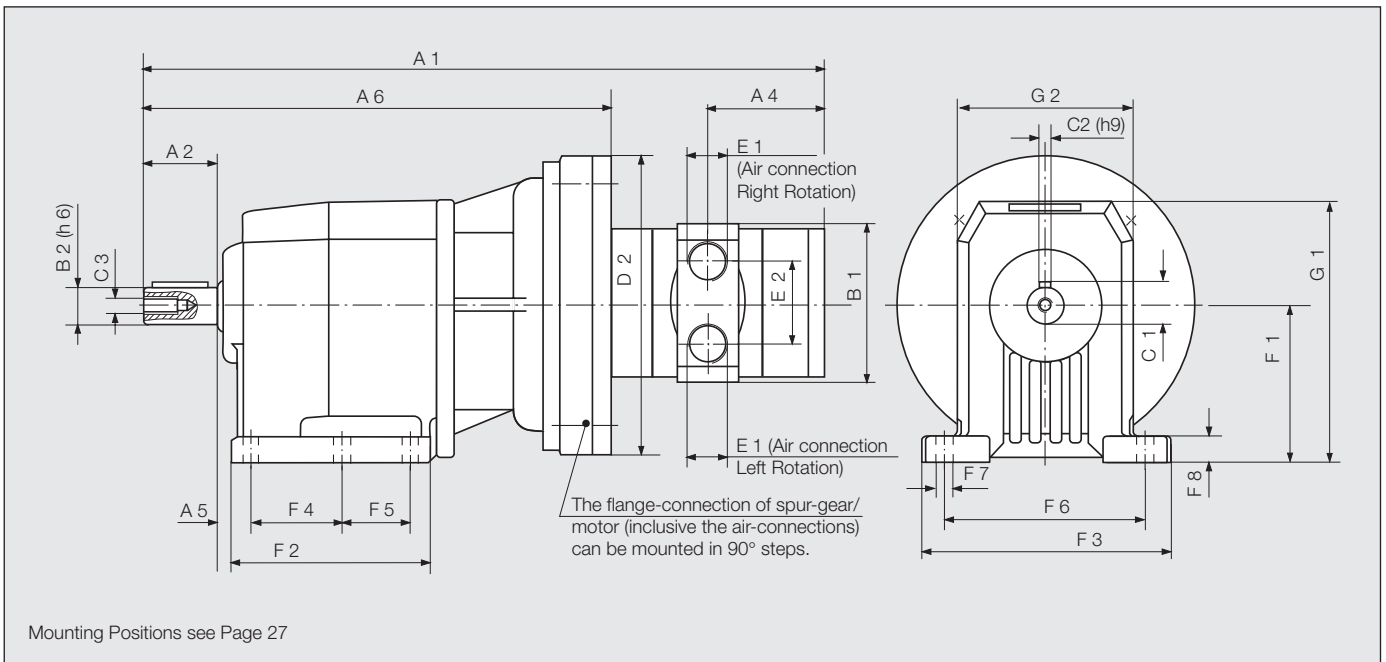

**Motor Size 11 with Spur-Gear**

Type	Dimensions of Bracket motor (mm)																						
	A1	A2	A4	A5	A6	B1	B2	C1	C2	C3	D2	E1	E2	F1	F2	F3	F4	F5	F6	F7	F8	G1	G2
68-S006..	423	40	81	18	275	102	20	22.5	6	M8	200	3/4"	58	85	107	130	50	37	110	9	15	141	95
68-S010..	451	50	81	18	303	102	25	28	8	M8	200	3/4"	58	100	137	155	60	47.5	130	11	17	166	110
68-S020..	485.5	60	81	18	337.5	102	30	33	8	M10	200	3/4"	58	110	156	190	70	60	160	11	20	181	130
68-S045..	515.5	70	81	20	367.5	102	35	38	10	M10	200	3/4"	58	130	185.5	216	105	-	180	14	18	221	155
68-S093..	541	80	81	25	393	102	40	43	12	M12	200	3/4"	58	155	200	270	110	-	225	18	22	278	185
68-S150..	596	100	81	25	448	102	50	53.5	14	M16	200	3/4"	58	195	222	232	145	-	250	18	25	316	210

## Technical Data

The motors in this design series can be operated in either right- or left rotation.

Alternatively, the motor can also be reversed by two external 3/2-way valves or one 5/3-way valve (each with sufficiently large cross-sections).

<b>Motor Size 13</b> without Gearing		<b>Flange motor</b>	
Motor, reversible by external valve	<b>type</b> order no.	<b>68-0013 / IEC 90 A</b> 444792 A	
Nominal-Power	kW / HP	3.6 / 4.8	
Nominal-Speed	rpm	3000	
Speed (idling)	rpm	6000	
Nominal-Torque	Nm / in.lbs	11.5 / 102	
Start-Torque min.	Nm / in.lbs	17 / 150	
Radial force max.	N / lbs	1900 / 425	
Axial force max.	N / lbs	900 / 200	
Air Consumption	m <sup>3</sup> /min / cfm	5.8 / 205	
Weight	kg / lbs	16.5 / 36	
Hose I. D.	mm / in.	25 / 1	

Performance data relate to an air pressure of 6 bar (85 PSI)

<b>Motor Size 13</b> with Planetary-Gear		<b>Flange motor</b>	
Motor, reversible by external valve	<b>type</b> order no.	<b>68 - P005F - 000 - 13</b> 444870 A	<b>68 - P010F - 000 - 13</b> 444870 B
Nominal-Power	kW / HP	3.6 / 4.8	3.6 / 4.8
Nominal-Speed	rpm	600	300
Speed (idling)	rpm	960 *)	480 *)
Nominal-Torque	Nm / in.lbs	55 / 486	100 <sup>1)</sup> / 885
Start-Torque min.	Nm / in.lbs	82 / 725	100 <sup>1)</sup> / 885
Radial force max.	N / lbs	2400 / 537	2400 / 537
Axial force max.	N / lbs	1900 / 425	1900 / 425
Air Consumption	m <sup>3</sup> /min / cfm	5.8 / 205	5.8 / 205
Weight	kg / lbs	25.5 / 56	25.5 / 56
Hose I. D.	mm / in.	25 / 1	25 / 1
Gear type		P120F	P120F
Max. gear torque for permanent load	Nm / in.lbs	100 / 885	100 <sup>1)</sup> / 885

Performance data relate to an air pressure of 6 bar (85 PSI)

\*) max. admissible Speed (idling)

<sup>1)</sup> Maximum torque 480 Nm for a maximum of 1000 cycles under load.

### Model Number Description

i.e.: 68 - P 005 F - 000 - 13

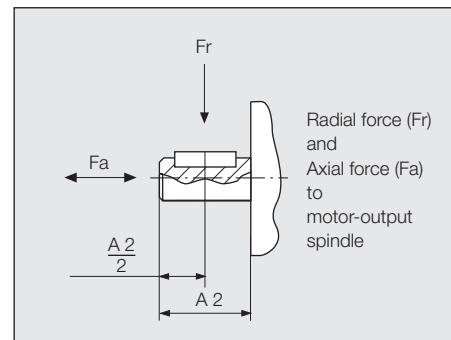
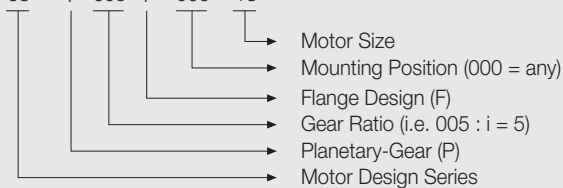

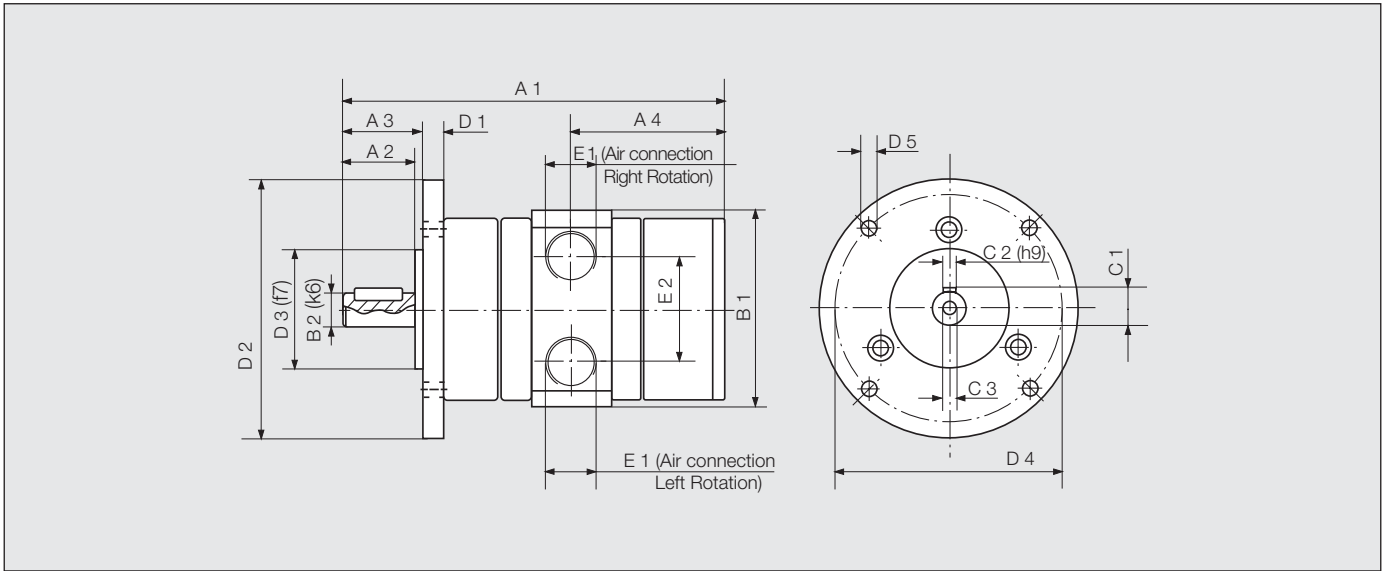

Motor Size 13 without Gearing																
Type	Dimensions of Flange motor (mm)															
	A1	A2	A3	A4	B1	B2	C1	C2	C3	D1	D2	D3	D4	D5	E1	E2
68-0013 / IEC 90 A	215	46.5	50	85	138	24	27	8	M8	11	200	130	165	11	1"	70

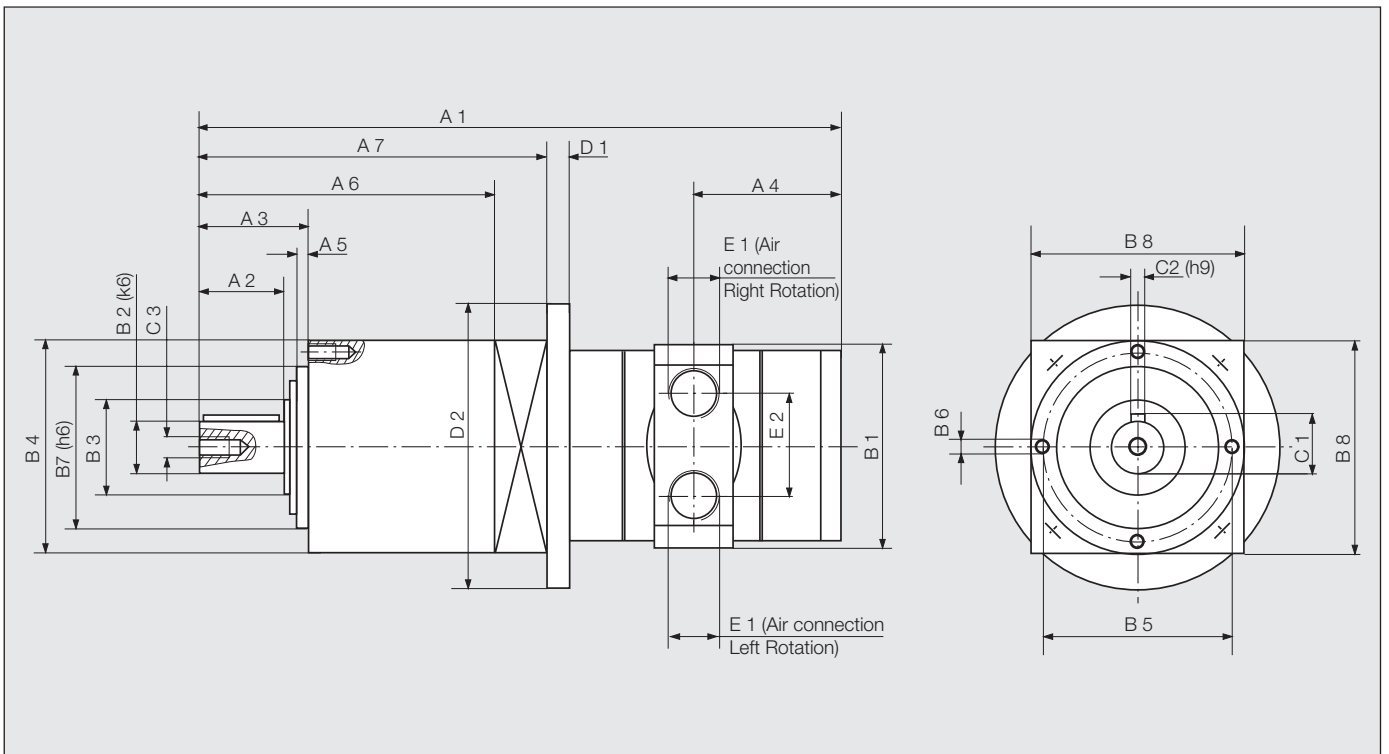

Motor Size 13 with Planetary-Gear													
Type	Dimensions of Flange motor (mm)												
	A1	A2	A3	A4	A5	A6	A7	B1	B2	B3	B4		
68-P005F-000-13	68-P010F-000-13	375	58	70	85	6	172	210	138	32	50	120	

Motor Size 13 with Planetary-Gear													
Type	Dimensions of Flange motor (mm)												
	B5	B6	B7	B8	C1	C2	C3	D1	D2	E1	E2		
68-P005F-000-13	68-P010F-000-13	108	M8	90	140	35	10	M12	11	200	1"	70	

## Technical Data

The motors in this design series can be operated in either right- or left rotation. Alternatively, the motor can also be reversed by two external 3/2-way valves or one 5/3-way valve (each with sufficiently large cross-sections).

<b>Motor Size 13</b> with Worm-Gear		<b>Flange motor</b>	<b>Bracket motor</b>
Motor, reversible by external valve	<b>type</b>  order no.	<b>68-W080</b> <b>F1- . . . -13</b> 444906 A - F <sup>1)</sup>	<b>68-W080</b> <b>KA- . . . -13</b> 444910 A - F <sup>1)</sup>
Nominal-Power	kW / HP	3.6 / 4.8	3.6 / 4.8
Nominal-Speed	rpm	37	37
Speed (idling)	rpm	62 <sup>2)</sup>	62 <sup>2)</sup>
Nominal-Torque	Nm / in.lbs	670 / 5929	670 / 5929
Start-Torque min.	Nm / in.lbs	480 / 4248	480 / 4248
For permissible radial and axial forces please check "optional accessories" on page 28			
Air Consumption	m <sup>3</sup> /min / cfm	5.8 / 205	5.8 / 205
Weight	kg / lbs	65.5 / 144	65.5 / 144
Hose I. D.	mm / in.	25 / 1	25 / 1
Gear type		W130F	W130K
Max. gear torque for permanent load	Nm / in.lbs	660 / 5841	660 / 5841

Performance data relate to an air pressure of 6 bar (85 PSI)

<sup>1)</sup> A / B / C / D / E / F = mounting position 0B3 / 0B6 / 0B7 / 0B8 / 0V5 / 0V6  
(Example: mounting position 0B6 = order no. XXXXXX B)  
<sup>2)</sup> max. admissible Speed (idling)

### Model Number (when ordering please indicate model designation)

i.e.: 68 - W 080 F1 - 0B3 - 13

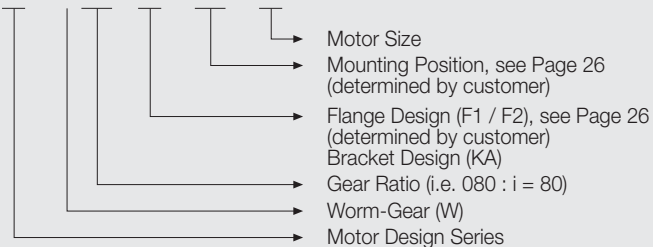

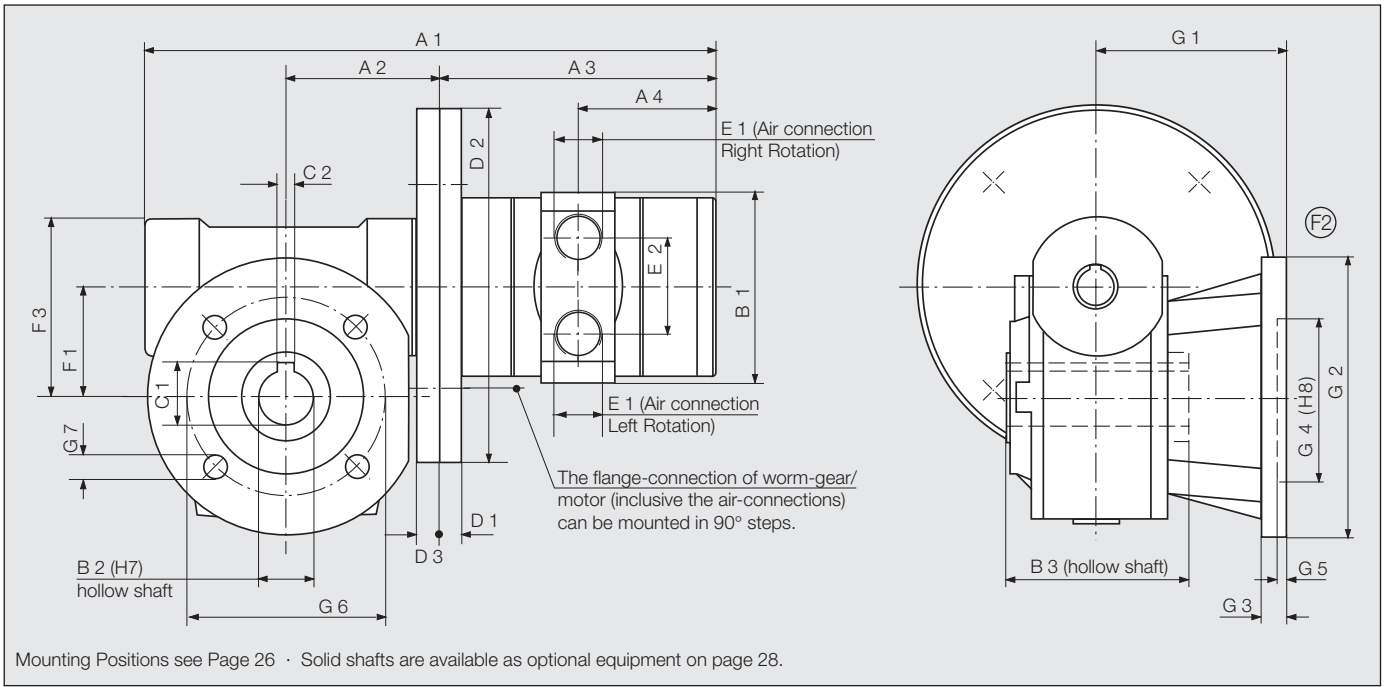

Motor Size 13 with Worm-Gear		Dimensions of Flange motor (mm)																					
Type	A1	A2	A3	A4	B1	B2	B3	C1	C2	D1	D2	D3	E1	E2	F1	F3	G1	G2	G3	G4	G5	G6	G7
68-W080..	504	185	165	85	138	45	165	48.8	14	11	200	17	1"	70	130	195	197.5	320	20	180	18	255	16 (8x)

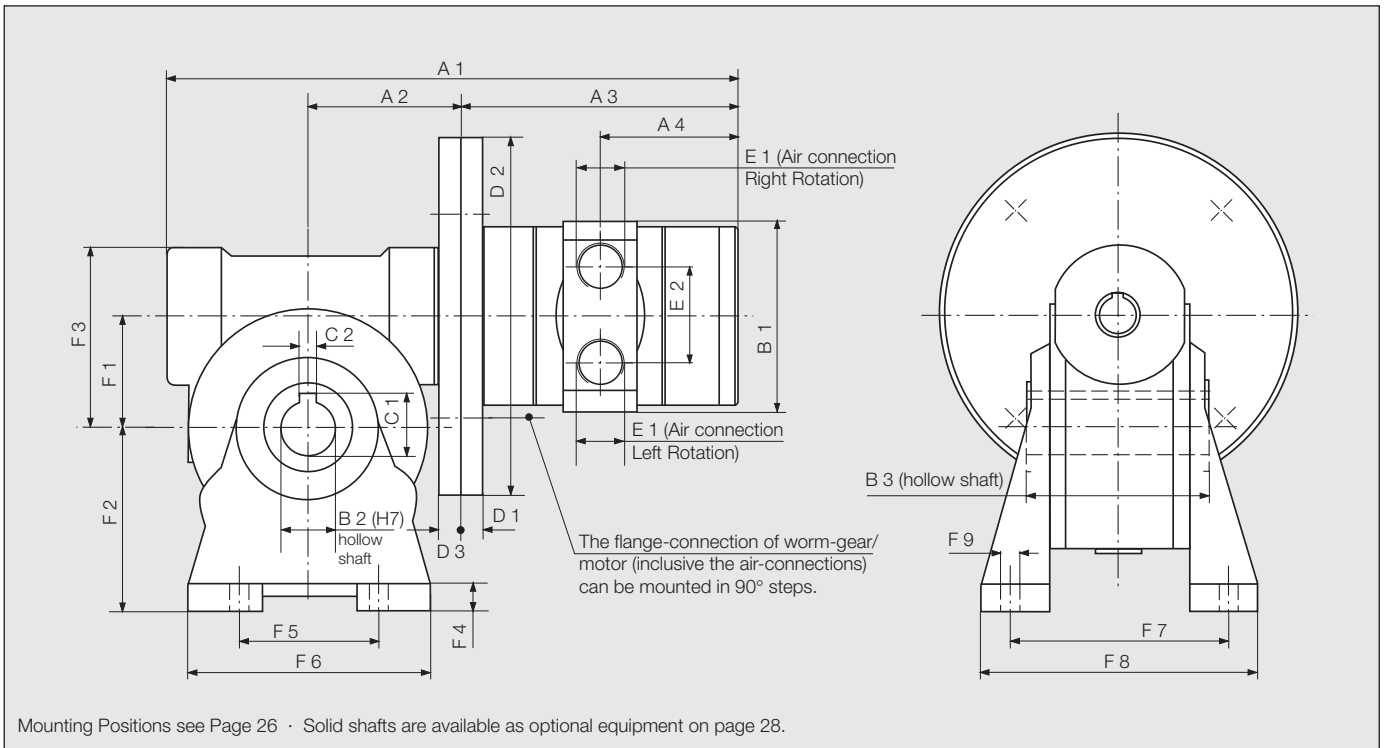

Motor Size 13 with Worm-Gear		Dimensions of Bracket motor (mm)																					
Type	A1	A2	A3	A4	B1	B2	B3	C1	C2	D1	D2	D3	E1	E2	F1	F2	F3	F4	F5	F6	F7	F8	F9
68-W080..	504	185	165	85	138	45	165	48.8	14	11	200	17	1"	70	130	195	195	18	220	310	191	245	16

## Technical Data

The motors in this design series can be operated in either right- or left rotation. Alternatively, the motor can also be reversed by two external 3/2-way valves or one 5/3-way valve (each with sufficiently large cross-sections).

Motor Size 13 with Worm gear		General-purpose housing		
Motor, reversible by external valve	<b>type</b>  order no.	<b>68-W010 U</b> <b>...-...-13</b> 446230 A - F <sup>1)</sup>	<b>68-W024U</b> <b>...-...-13</b> 446231 A - F <sup>1)</sup>	<b>68-W040U</b> <b>...-...-13</b> 446232 A - F <sup>1)</sup>
Nominal-Power	kW / HP	3.6 / 4.8	3.6 / 4.8	3.6 / 4.8
Nominal-Speed	rpm	300	130	75
Speed (idling)	rpm	500 <sup>2)</sup>	220 <sup>2)</sup>	125 <sup>2)</sup>
Nominal-Torque	Nm / in.lbs	98 / 867	224 / 1982	368 / 3257
Start-Torque min.	Nm / in.lbs	113 / 1000	230 / 2035	317 / 2805
For permissible radial and axial forces please check "optional accessories" on page 28				
Air Consumption	m <sup>3</sup> /min / cfm	5.8 / 205	5.8 / 205	5.8 / 205
Weight	kg / lbs	22.9 / 50.4	31 / 68.2	55 / 121
Hose I. D.	mm / in.	25 / 1	25 / 1	25 / 1
Gear type		W63U	W86U	W110U
Max. gear torque for permanent load	Nm / in.lbs	125 / 1106	285 / 2522	595 / 5266

Performance data relate to an air pressure of 6 bar (85 PSI)

<sup>1)</sup> A / B / C / D / E / F = mounting position 0B3 / 0B6 / 0B7 / 0B8 / 0V5 / 0V6  
(Example: mounting position 0B6 = order no. XXXXXX B)

<sup>2)</sup> max. admissible Speed (idling)

### Model Number Description (when ordering please indicate model designation)

i.e.: 68 - W010U F1 - 0B3 - 13

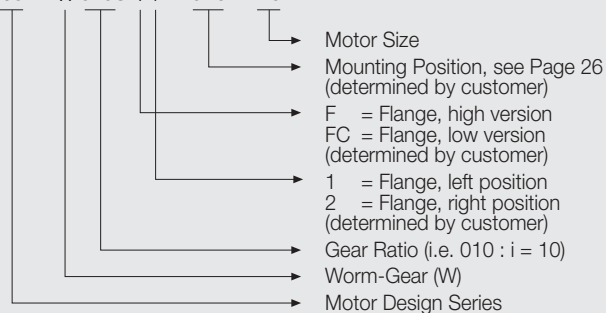

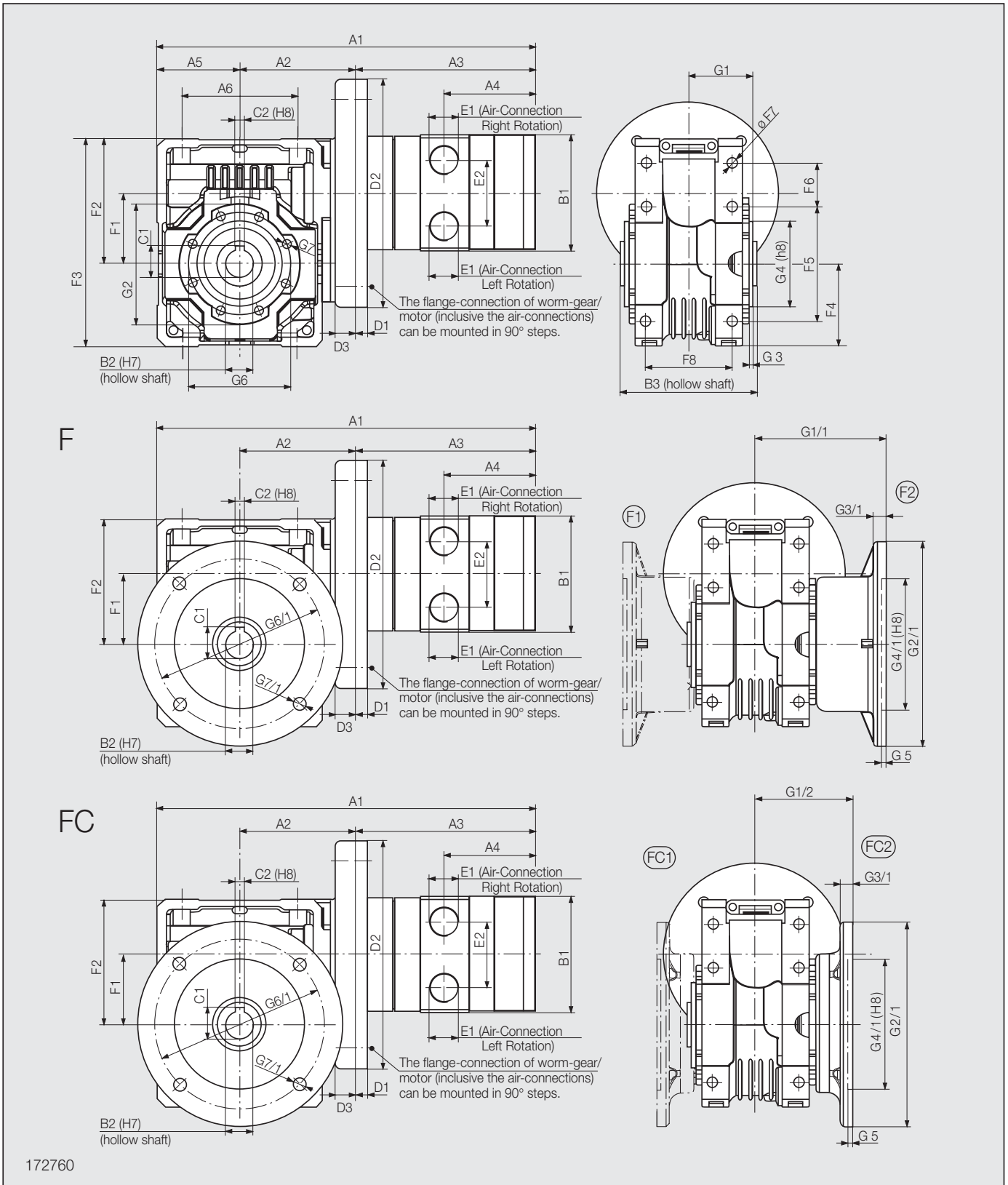

172760

Motor Size 13 with Worm-Gear																				
Type	Dimensions of Flange motor (mm)																			
	A1	A2	A3	A4	A5	A6	B1	B2	B3	C1	C2	D1	D2	D3	E1	E2	F1	F2	F3	F4
68-W010U	334.5	102	165	85	72.5	102	138	25	120	28.3	8	11	200	12	1"	70	62.17	110	182.5	72.5
68-W024U	393	128	165	85	100	144	138	35	140	38.3	10	11	200	12	1"	70	86.9	145.5	245.5	100
68-W040U	433	143	165	85	125	174	138	42	155	45.3	12	11	200	12	1"	70	110.1	183	308	125
	F5	F6	F7	F8	G1	G1/1	G1/2	G2	G2/1	G3	G3/1	G4	G4/1	G5	G6	G6/1	G7			G7/1
68-W010U	102	37.5	9	76	56	116	86	105	180	3	11	75	115	5	90	150	M8x14		11	
68-W024U	144	45.5	11.5	101	68	151	110.5	150	210	3.5	15	110	152	6	130	176	M10x18		12.5	
68-W040U	184	58	14	115	76.5	179.5	131.5	200	280	3.5	20	130	170	12	165	230	M12x19		13	

Flange F and FC are "optional accessories".

# Technical Data

The motors in this design series can be operated in either right- or left rotation. Alternatively, the motor can also be reversed by two external 3/2-way valves or one 5/3-way valve (each with sufficiently large cross-sections).

Motor Size 13 with Spur-Gear		Flange motor					
Motor, reversible by external valve	<b>type</b> order no.	<b>68-S005</b> <b>F- ... -13</b> 444891 A - C <sup>1)</sup>	<b>68-S010</b> <b>F- ... -13</b> 444892 A - C <sup>1)</sup>	<b>68-S020</b> <b>F- ... -13</b> 444893 A - C <sup>1)</sup>	<b>68-S040</b> <b>F- ... -13</b> 444894 A - C <sup>1)</sup>	<b>68-S083</b> <b>F- ... -13</b> 444895 A - C <sup>1)</sup>	<b>68-S169</b> <b>F- ... -13</b> 444896 A - C <sup>1)</sup>
Nominal-Power	kW / HP	3.6 / 4.8	3.6 / 4.8	3.6 / 4.8	3.6 / 4.8	3.6 / 4.8	3.6 / 4.8
Nominal-Speed	rpm	625	310	150	74	36	18
Speed (idling)	rpm	1050 <sup>2)</sup>	520 <sup>2)</sup>	250 <sup>2)</sup>	125 <sup>2)</sup>	60 <sup>2)</sup>	30 <sup>2)</sup>
Nominal-Torque	Nm / in.lbs	52 / 460	105 / 929	216 / 1912	441 / 3903	888 / 7859	1800 / 15930
Start-Torque	min. Nm / in.lbs	78 / 690	155 / 1372	320 / 2832	652 / 5770	1312 / 11611	2670 / 23629
Radial force	max. N / lbs	1370 / 307	2580 / 578	3880 / 869	8870 / 1987	14500 / 3248	35000 / 7840
Axial force	max. N / lbs	274 / 61	516 / 116	776 / 174	1770 / 396	2900 / 650	7000 / 1568
Air Consumption	m <sup>3</sup> /min / cfm	5.8 / 205	5.8 / 205	5.8 / 205	5.8 / 205	5.8 / 205	5.8 / 205
Weight	kg / lbs	24.6 / 54.1	24.6 / 54.1	45 / 99	63.5 / 139.7	77.5 / 170.5	151.5 / 333.3
Hose I. D.	mm / in.	25 / 1	25 / 1	25 / 1	25 / 1	25 / 1	25 / 1
Gear type		S212F	S312F	S412F	S512F	S613F	S803F
Max. gear torque for permanent load	Nm / in.lbs	80 / 708	175 / 1549	385 / 3407	800 / 7080	1600 / 14160	4000 / 35400

Performance data relate to an air pressure of 6 bar (85 PSI)

<sup>1)</sup> A / B / C = mounting position 0B5 / 0V1 / 0V3  
(Example: mounting position 0V1 = order no. XXXXXX B)  
<sup>2)</sup> max. admissible Speed (idling)

Motor Size 13 with Spur-Gear		Bracket motor					
Motor, reversible by external valve	<b>type</b> order-no.	<b>68-S005</b> <b>K- ... -13</b> 444897 A - F <sup>1)</sup>	<b>68-S010</b> <b>K- ... -13</b> 444898 A - F <sup>1)</sup>	<b>68-S020</b> <b>K- ... -13</b> 444899 A - F <sup>1)</sup>	<b>68-S040</b> <b>K- ... -13</b> 444900 A - F <sup>1)</sup>	<b>68-S083</b> <b>K- ... -13</b> 444901 A - F <sup>1)</sup>	<b>68-S169</b> <b>K- ... -13</b> 444902 A - F <sup>1)</sup>
Nominal-Power	kW / HP	3.6 / 4.8	3.6 / 4.8	3.6 / 4.8	3.6 / 4.8	3.6 / 4.8	3.6 / 4.8
Nominal-Speed	rpm	625	310	150	74	36	18
Speed (idling)	rpm	1050 <sup>2)</sup>	520 <sup>2)</sup>	250 <sup>2)</sup>	125 <sup>2)</sup>	60 <sup>2)</sup>	30 <sup>2)</sup>
Nominal-Torque	Nm / in.lbs	52 / 460	105 / 929	216 / 1912	441 / 3903	888 / 7859	1800 / 15930
Start-Torque	min. Nm / in.lbs	78 / 690	155 / 1372	320 / 2832	652 / 5770	1312 / 11611	2670 / 23629
Radial force	max. N / lbs	1370 / 307	2580 / 578	3880 / 869	8870 / 1987	14500 / 3248	35000 / 7840
Axial force	max. N / lbs	274 / 61	516 / 116	776 / 174	1770 / 396	2900 / 650	7000 / 1568
Air Consumption	m <sup>3</sup> /min / cfm	5.8 / 205	5.8 / 205	5.8 / 205	5.8 / 205	5.8 / 205	5.8 / 205
Weight	kg / lbs	24.6 / 54.1	24.6 / 54.1	45 / 99	63.5 / 139.7	77.5 / 170.5	151.5 / 333.3
333.3Hose I. D.	mm / in.	25 / 1	25 / 1	25 / 1	25 / 1	25 / 1	25 / 1
Gear type		S212K	S312K	S412K	S512K	S613K	S803K
Max. gear torque for permanent load	Nm / in.lbs	80 / 708	175 / 1549	385 / 3407	800 / 7080	1600 / 14160	4000 / 35400

Performance data relate to an air pressure of 6 bar (85 PSI)

<sup>1)</sup> A / B / C / D / E / F = mounting position 0B3 / 0B6 / 0B7 / 0B8 / 0V5 / 0V6  
(Example: mounting position 0B7 = order no. XXXXXX C)  
<sup>2)</sup> max. admissible Speed (idling)

## Model Number Description (when ordering please indicate model designation)

i.e.: 68 - S 005 F - 0B5 - 13

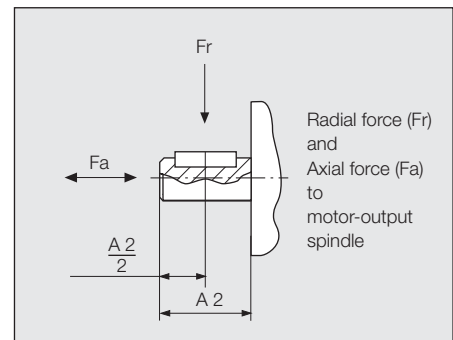
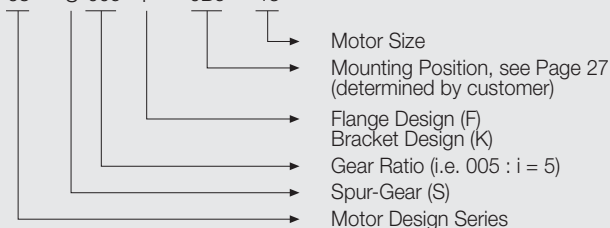

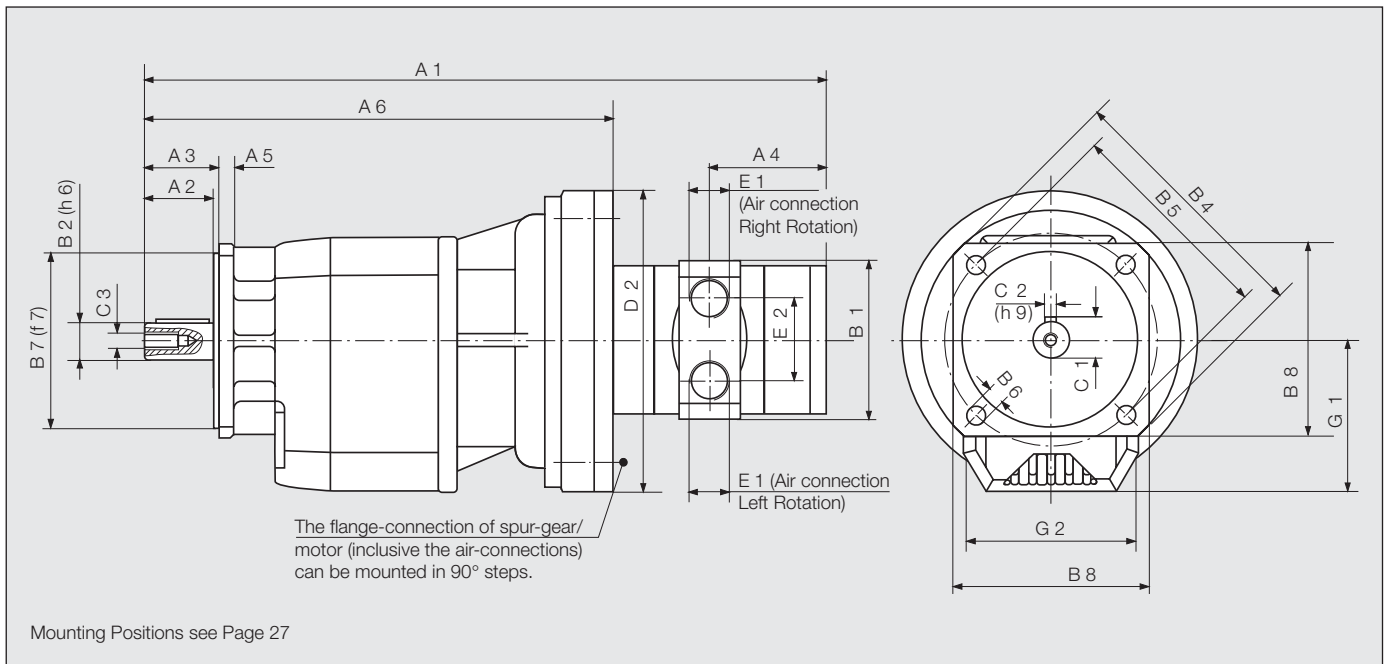

**Motor Size 13 with Spur-Gear**

Type	Dimensions of Flange motor (mm)																				
	A1	A2	A3	A4	A5	A6	B1	B2	B4	B5	B6	B7	B8	C1	C2	C3	D2	E1	E2	G1	G2
68-S005..	457	46.5	50	85	10	303	138	25	160	130	9.5	110	135	28	8	M8	200	1"	70	92	110
68-S010..	491.5	56.5	60	85	13	337.5	138	30	200	165	11.5	130	150	33	8	M10	200	1"	70	108	130
68-S020..	521.5	66	70	85	13	367.5	138	35	250	215	14	180	—	38	10	M10	200	1"	70	128	155
68-S040..	547	76	80	85	16	393	138	40	300	265	14	230	—	43	12	M12	200	1"	70	152	185
68-S083..	602	96	100	85	16	448	138	50	300	265	14	230	—	53.5	14	M16	200	1"	70	178.5	210
68-S169..	701	135	140	85	20	545	138	80	400	350	18	300	350	85	22	M20	200	1"	70	247	320

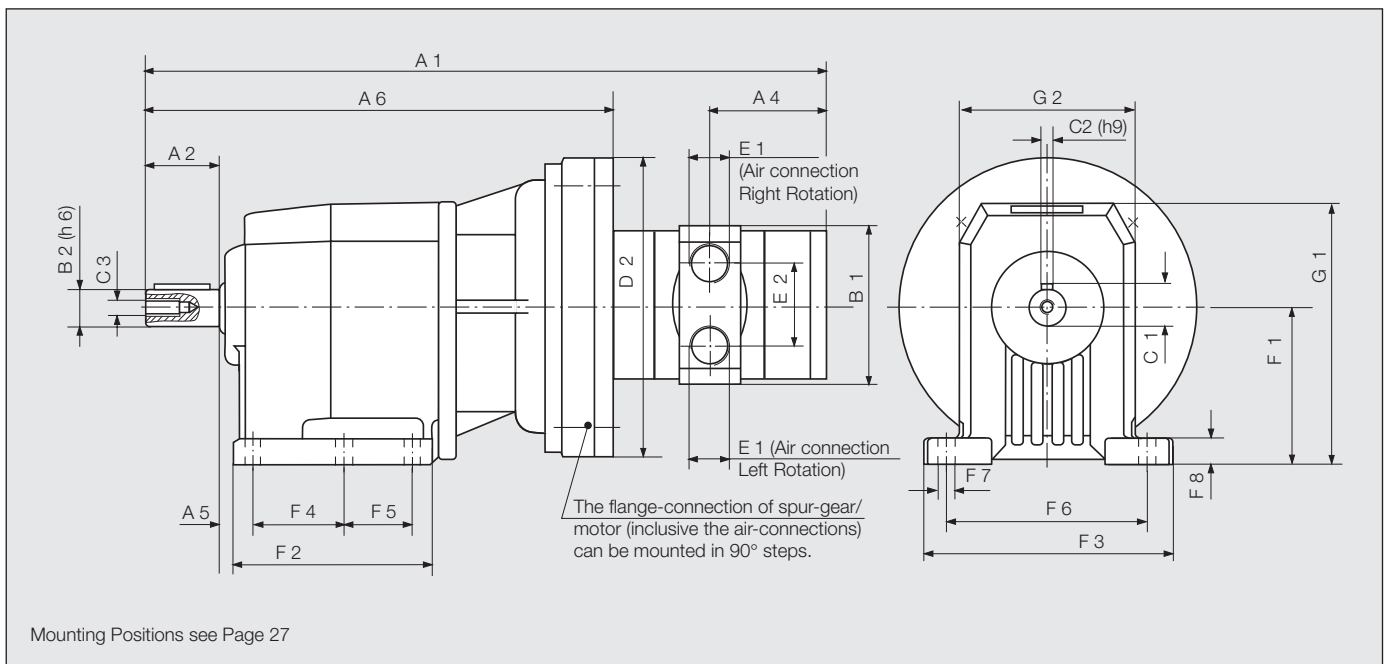

**Motor Size 13 with Spur-Gear**

Type	Dimensions of Bracket motor (mm)																						
	A1	A2	A4	A5	A6	B1	B2	C1	C2	C3	D2	E1	E2	F1	F2	F3	F4	F5	F6	F7	F8	G1	G2
68-S005..	457	50	85	18	303	138	25	28	8	M8	200	1"	70	100	137	155	60	47.5	130	11	17	166	110
68-S010..	491.5	60	85	18	337.5	138	30	33	8	M10	200	1"	70	110	156	190	70	60	160	11	20	181	130
68-S020..	521.5	70	85	20	367.5	138	35	38	10	M10	200	1"	70	130	185.5	216	149.5	—	180	14	18	221	155
68-S040..	547	80	85	25	393	138	40	43	12	M12	200	1"	70	155	200	270	156	—	225	18	22	278	185
68-S083..	602	100	85	25	448	138	50	53.5	14	M16	200	1"	70	195	232	300	180	—	250	18	25	316	210
68-S169..	701	140	85	33	545	138	80	85	22	M20	200	1"	70	250	277	440	210	—	370	26	35	420	320

**Mounting Positions**  
**Flange Layout - (F1) / (F2)**  
 for flange-motors with worm gears

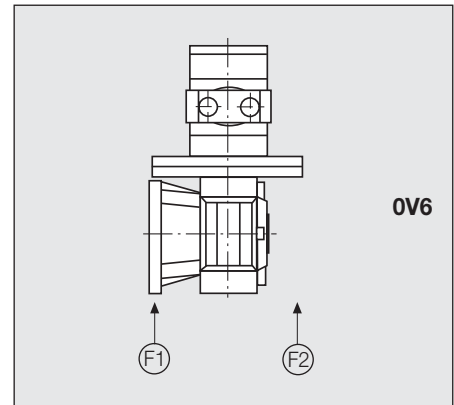
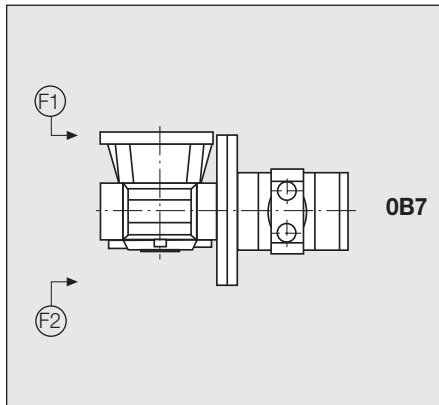
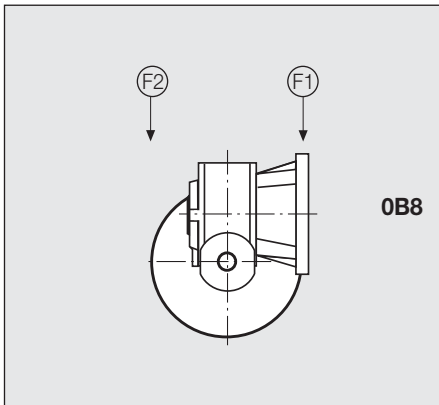
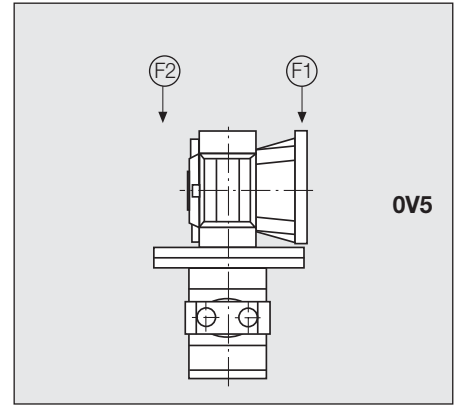
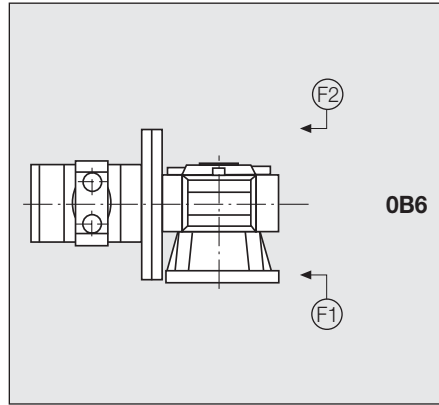
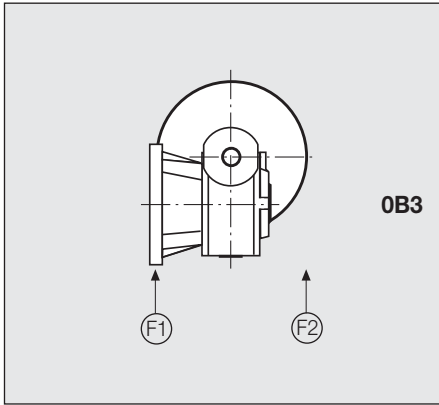

**Mounting Positions**  
 for bracket-motors with worm-gears

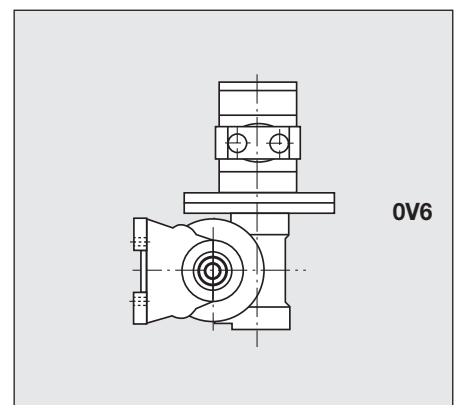
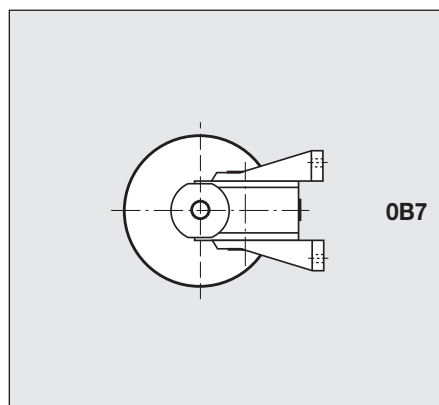
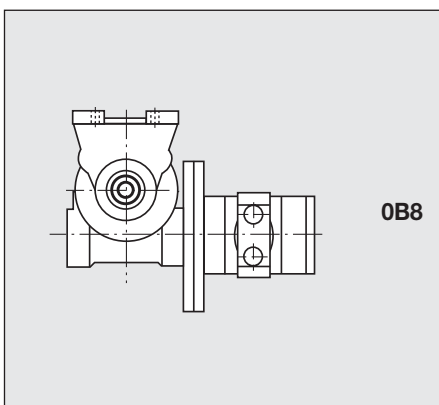
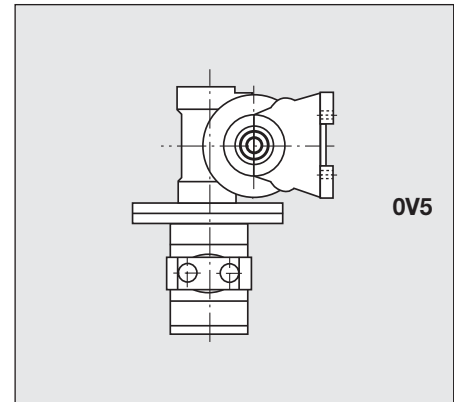
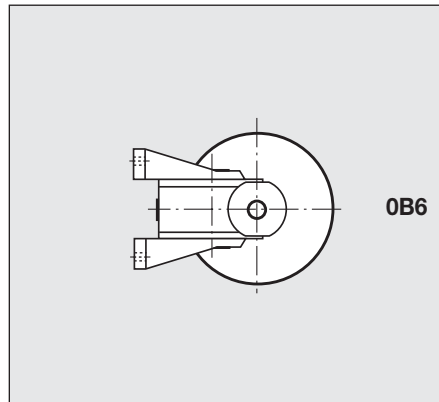
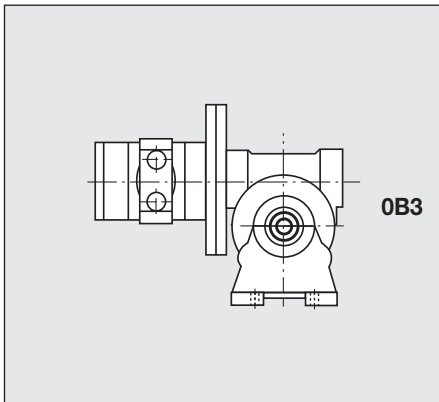

## Mounting Positions

for flange-motors with spur-gears

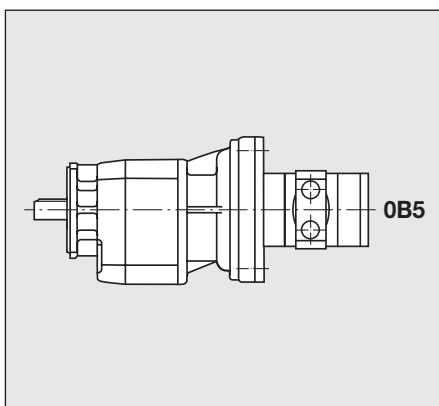
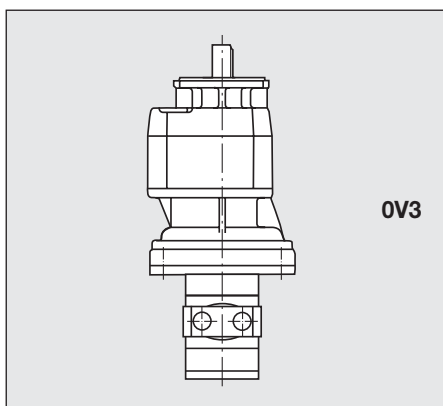
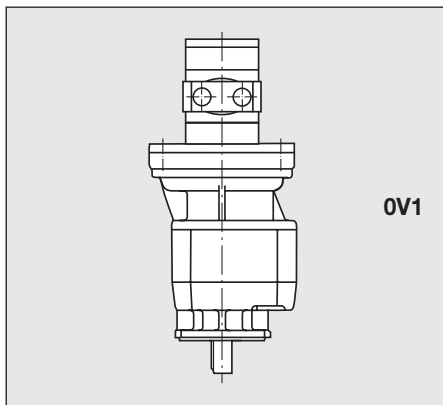

## Mounting Positions

for bracket-motors with spur-gears

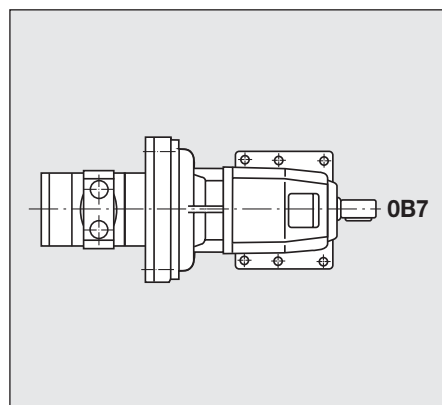
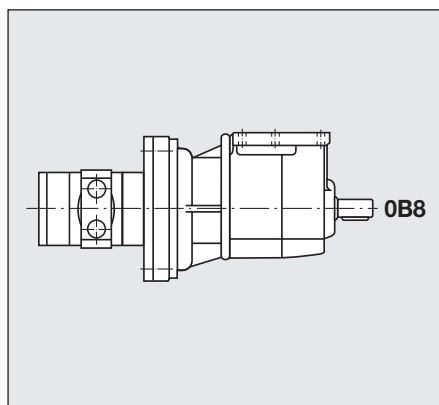
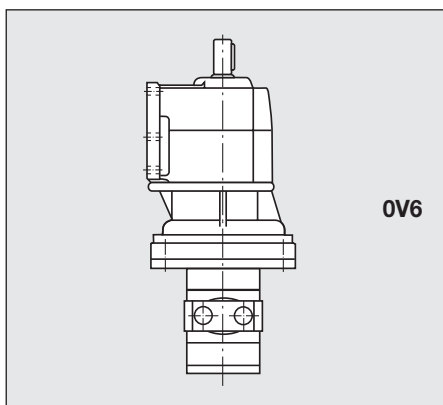
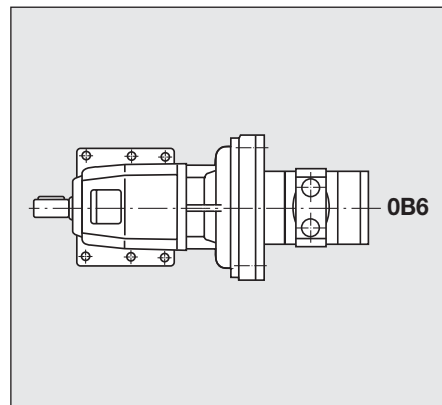
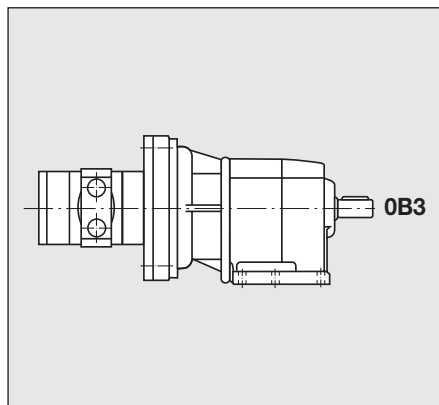
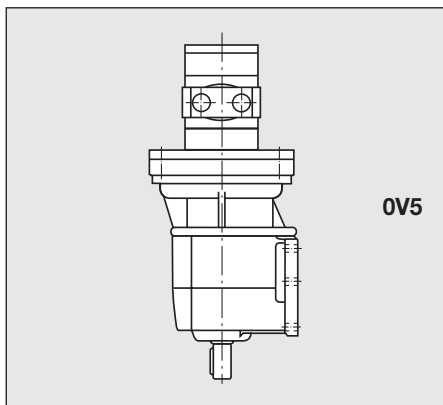

## Optional Equipment

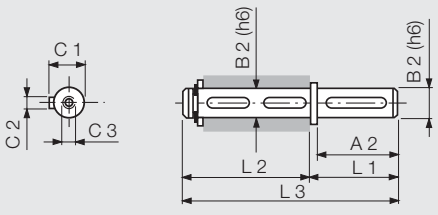
	Spindle (for motors with worm-gear)										
	order no.	for hollow shaft mm	Radial force max. N / lbs	Axial force max. N / lbs	Dimensions (mm)						
					A2	B2	C1	C2	C3	L1	L2
824328	Ø25 x 82	3450/ 770	690/150	60	25	28	8	M8	65	89	154
824329	Ø25 x 120	4700/1050	940/210	60	25	28	8	M8	65	127	192
824330	Ø35 x 140	7000/1560	1400/310	60	35	38	10	M10	65	149	214
824331	Ø42 x 155	8000/1790	1600/355	75	42	45	12	M12	80	164	244
824332	Ø45 x 165	13800/3090	2760/615	80	45	48.5	12	M12	85	176	261

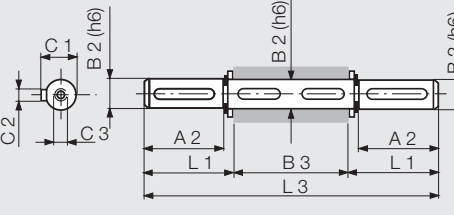
	Spindle (for motors with worm-gear)										
	order no.	for hollow shaft mm	Radial force max. N/lbs	Axial force max. N/lbs	Dimensions (mm)						
					A2	B2	B3	C1	C2	C3	L1
824333	Ø25 x 82	3450/ 770	690/150	60	25	82	28	8	M8	63.2	208.4
824334	Ø25 x 120	4700/1050	940/210	60	25	120	28	8	M8	63.2	246.4
824335	Ø35 x 140	7000/1560	1400/310	60	35	140	38	10	M10	64	268
824336	Ø42 x 155	8000/1790	1600/355	75	42	155	45	12	M12	79.2	313.5
824337	Ø45 x 165	13800/3090	2760/615	80	45	165	48.5	14	M12	84.7	334.5

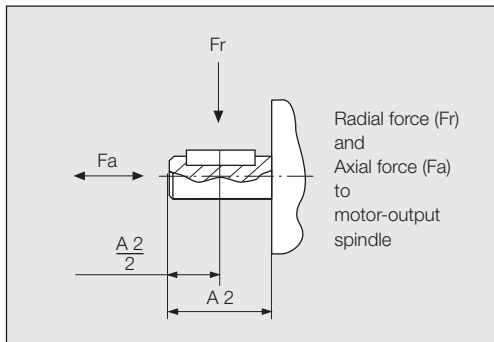

Appropriate for each Motor	Model	68-009	68-0011	68-0013
Spare Parts Kit	order no.	445033 A	445034 A	445035 A
Consisting of: Bearing, Vanes, Springs and Seal rings				
Silencer Set including connection	order no.	440021 A	440022 A	440023 A

## Optional Equipment

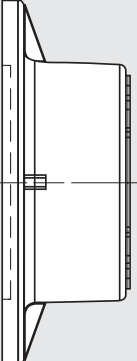
	<b>Flange (for motors with worm-gear) high version</b>	
	Type of gearing	order no.
	W 63 U	830929
	W 86 U	830931
W 110 U	830934	

	<b>Flange (for motors with worm-gear) low version</b>	
	Type of gearing	order no.
	W 63 U	830930
	W 86 U	830932
W 110 U	830935	

## Technical Data

The motors in this design series can be operated in either right- or left rotation. Alternatively, the motor can also be reversed by two external 3/2-way valves or one 5/3-way valve (each with sufficiently large cross-sections).

Motor Size 32		Flange motor				Bracket motor			
Motor, reversible by external valve	<b>type</b> order no.	<b>FM 32 SF</b> 442241 A	<b>FM 32 LF</b> 442242 A	<b>FM 32 LLFA</b> 442243 A	<b>FM 32 LLFB</b> 442244 A	<b>KM 32 SF</b> 442245 A	<b>KM 32 LF</b> 442246 A	<b>KM 32 LLFA</b> 442247 A	<b>KM 32 LLFB</b> 442248 A
Nominal-Power	kW / HP	1.6 / 2.1	1.6 / 2.1	1.6 / 2.1	1.6 / 2.1	1.6 / 2.1	1.6 / 2.1	1.6 / 2.1	1.6 / 2.1
Nominal-Speed	rpm	3400	340	170	100	3400	340	170	100
Speed (idling)	rpm	6800	680	340	200	6800	680	340	200
Nominal-Torque	Nm / in.lbs	4.5 / 40	45 / 398	90 / 796	153 / 1354	4.5 / 40	45 / 398	90 / 796	153 / 1354
Start-Torque min.	Nm / in.lbs	6.7 / 59	67 / 593	135 / 1195	229 / 2027	6.7 / 59	67 / 593	135 / 1195	229 / 2027
Air Consumption	m <sup>3</sup> /min / cfm	1.9 / 67	1.9 / 67	1.9 / 67	1.9 / 67	1.9 / 67	1.9 / 67	1.9 / 67	1.9 / 67
Weight	kg / lbs	10 / 22	15 / 33	18 / 40	18 / 40	11 / 24	16 / 35	19 / 42	19 / 42
Hose I.D.	mm / in.	15 / <sup>5</sup> / <sub>8</sub>	15 / <sup>5</sup> / <sub>8</sub>	15 / <sup>5</sup> / <sub>8</sub>	15 / <sup>5</sup> / <sub>8</sub>	15 / <sup>5</sup> / <sub>8</sub>	15 / <sup>5</sup> / <sub>8</sub>	15 / <sup>5</sup> / <sub>8</sub>	15 / <sup>5</sup> / <sub>8</sub>

Motor Size 50		Flange motor				Bracket motor			
Motor, reversible by external valve	<b>type</b> order no.	<b>FM 50 SF</b> 442229 A	<b>FM 50 LF</b> 442230 A	<b>FM 50 LLFA</b> 442107 A	<b>FM 50 LLFB</b> 442115 A	<b>KM 50 SF</b> 442233 A	<b>KM 50 LF</b> 442234 A	<b>KM 50 LLFA</b> 442235 A	<b>KM 50 LLFB</b> 442236 A
Nominal-Power	kW / HP	2.6 / 3.5	2.5 / 3.3	2.5 / 3.3	2.5 / 3.3	2.6 / 3.5	2.5 / 3.3	2.5 / 3.3	2.5 / 3.3
Nominal-Speed	rpm	3000	240	100	75	3000	240	100	75
Speed (idling)	rpm	6000	480	200	150	6000	480	200	150
Nominal-Torque	Nm / in.lbs	8.3 / 73	99 / 876	239 / 2115	318 / 2814	8.3 / 73	99 / 876	239 / 2115	318 / 2814
Start-Torque min.	Nm / in.lbs	12 / 106	148 / 1310	358 / 3168	477 / 4221	12 / 106	148 / 1310	358 / 3168	477 / 4221
Air Consumption	m <sup>3</sup> /min / cfm	3.6 / 127	3.6 / 127	3.6 / 127	3.6 / 127	3.6 / 127	3.6 / 127	3.6 / 127	3.6 / 127
Weight	kg / lbs	15 / 33	20 / 44	23 / 51	23 / 51	16 / 35	21 / 46	25 / 55	25 / 55
Hose I.D.	mm / in.	19 / <sup>3</sup> / <sub>4</sub>	19 / <sup>3</sup> / <sub>4</sub>	19 / <sup>3</sup> / <sub>4</sub>	19 / <sup>3</sup> / <sub>4</sub>	19 / <sup>3</sup> / <sub>4</sub>	19 / <sup>3</sup> / <sub>4</sub>	19 / <sup>3</sup> / <sub>4</sub>	19 / <sup>3</sup> / <sub>4</sub>

Motor Size 52		Flange motor				Bracket motor			
Motor, reversible by external valve	<b>type</b> order no.	<b>FM 52 SF</b> 442231 A	<b>FM 52 LF</b> 442232 A	<b>FM 52 LLFA</b> 442116 A	<b>FM 52 LLFB</b> 442114 A	<b>KM 52 SF</b> 442237 A	<b>KM 52 LF</b> 442238 A	<b>KM 52 LLFA</b> 442239 A	<b>KM 52 LLFB</b> 442240 A
Nominal-Power	kW / HP	3.6 / 4.8	3.5 / 4.7	3.5 / 4.7	3.5 / 4.7	3.6 / 4.8	3.5 / 4.7	3.5 / 4.7	3.5 / 4.7
Nominal-Speed	rpm	2800	240	100	75	2800	240	100	75
Speed (idling)	rpm	5600	480	200	150	5600	480	200	150
Nominal-Torque	Nm / in.lbs	12 / 106	139 / 1230	334 / 2956	446 / 3947	12 / 106	139 / 1230	334 / 2956	446 / 3947
Start-Torque min.	Nm / in.lbs	18 / 159	208 / 1841	500 / 4425	670 / 5930	18 / 159	208 / 1841	500 / 4425	670 / 5930
Air Consumption	m <sup>3</sup> /min / cfm	5 / 176	5 / 176	5 / 176	5 / 176	5 / 176	5 / 176	5 / 176	5 / 176
Weight	kg / lbs	17 / 37	22 / 48	25 / 55	25 / 55	18 / 40	23 / 51	27 / 59	27 / 59
Hose I.D.	mm / in.	25 / 1	25 / 1	25 / 1	25 / 1	25 / 1	25 / 1	25 / 1	25 / 1

Performance data relate to an air pressure of 6 bar (85 PSI)

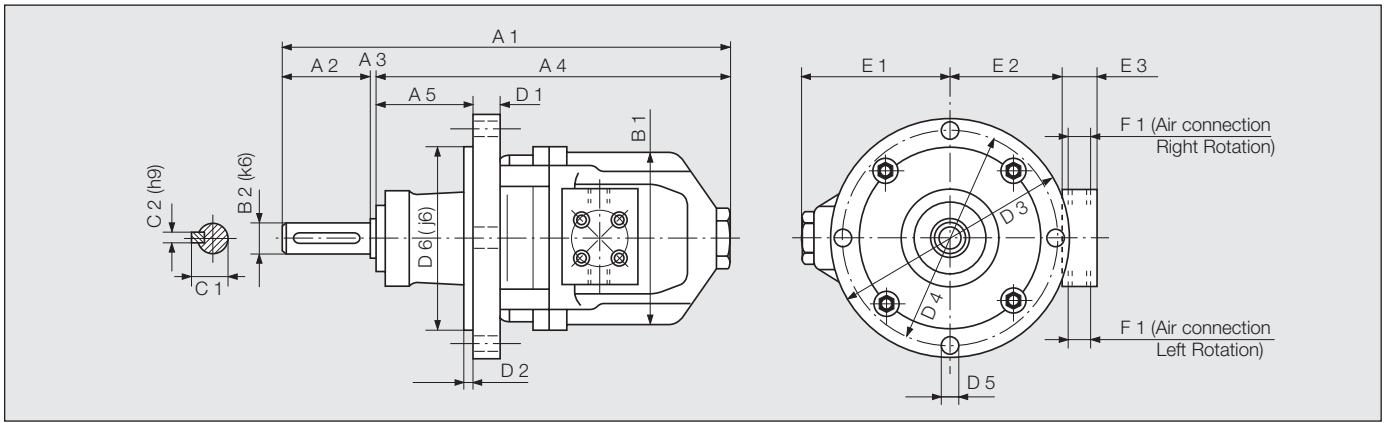

Motor Size	Type	Dimensions of Flange motor (mm)																		
		A1	A2	A3	A4	A5	B1	B2	C1	C2	D1	D2	D3	D4	D5	D6	E1	E2	E3	F1
32	FM 32 SF	200	50	3	147	4	132	25	27.9	8	22	4	190	160	14	138	110	118	50	1"
	FM 32 LF	289	50	2	237	64	132	25	27.9	8	22	5	190	160	14	138	110	118	50	1"
	FM 32 LLFA/B	371	50	2	319	105	132	30	32.9	8	22	5	190	160	14	138	110	118	50	1"
50	FM 50 SF	245	60	3	182	5	158	30	32.9	8	22	5	220	195	14	165	108	130	50	1"
	FM 50 LF	367	60	-	307	96	158	35	38.3	10	22	5	220	195	14	165	108	130	50	1"
	FM 50 LLFA/B	437	60	-	377	114	158	40	43.1	12	22	5	220	195	14	165	108	130	50	1"
52	FM 52 SF	266	60	3	203	5	158	30	32.9	8	22	5	220	195	14	165	108	130	50	1"
	FM 52 LF	388	60	-	328	96	158	35	38.3	10	22	5	220	195	14	165	108	130	50	1"
	FM 52 LLFA/B	458	60	-	398	114	158	40	43.1	12	22	5	220	195	14	165	108	130	50	1"

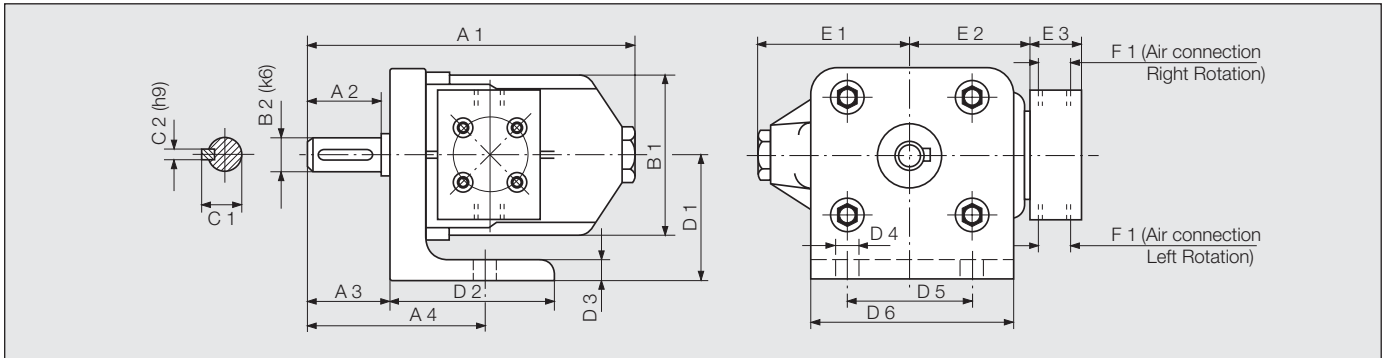

Motor Size	Type	Dimensions of Bracket motor (mm)																		
		A1	A2	A3	A4	B1	B2	C1	C2	D1	D2	D3	D4	D5	D6	E1	E2	E3	F1	
32	KM 32 SF	200	50	53	118	132	25	27.9	8	105	115	13	14	90	150	110	118	50	1"	
50	KM 50 SF	245	60	63	143	158	30	32.9	8	120	130	13	14	116	182	108	130	50	1"	
52	KM 52 SF	264	60	63	143	158	30	32.9	8	120	130	13	14	116	182	108	130	50	1"	

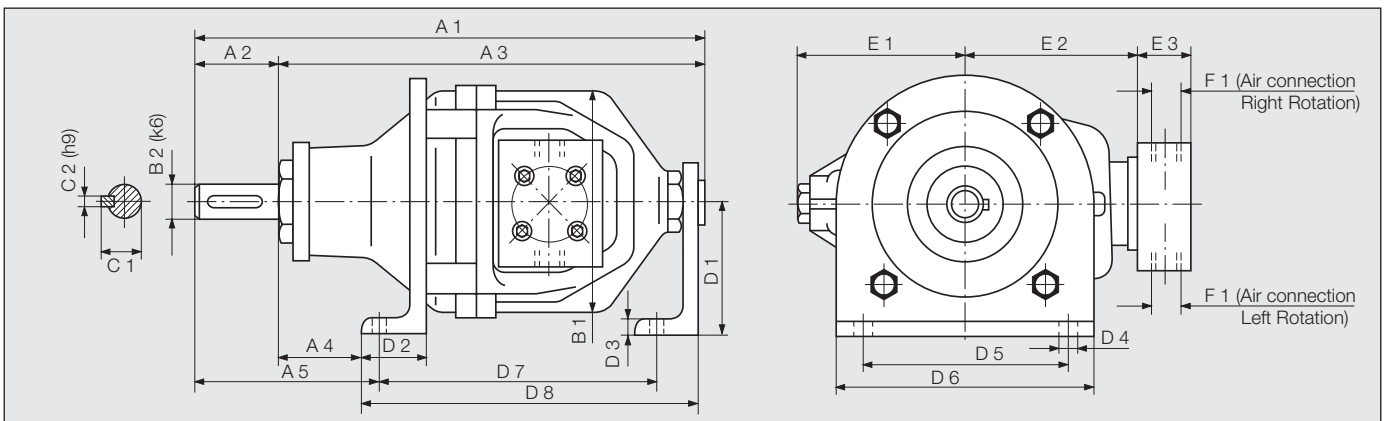

Motor Size	Type	Dimensions of Bracket motor (mm)																				
		A1	A2	A3	A4	A5	B1	B2	C1	C2	D1	D2	D3	D4	D5	D6	D7	D8	E1	E2	E3	F1
32	KM 32 LF	306	50	255	41	106	132	25	27.9	8	93	50	13	13	120	160	163	213	110	118	50	1"
	KM 32 LLFA/B	386	50	336	74	139	132	30	32.9	8	93	50	13	13	120	160	210	260	110	118	50	1"
50	KM 50 LF	384	60	324	66	141	161	35	38.3	10	100	50	13	13	150	190	204	254	108	131	50	1"
	KM 50 LLFA/B	454	60	394	32	122	161	40	43.1	12	100	45	13	13	120	160	264	359	115	131	50	1"
52	KM 52 LF	406	60	346	66	141	161	35	38.3	10	100	50	13	13	150	190	226	276	108	131	50	1"
	KM 52 LLFA/B	474	60	414	32	122	161	40	43.1	12	100	45	13	13	120	160	284	379	115	131	50	1"

## Technical Data

The motors in this design series can be operated in either right- or left rotation. Reverse is initiated by the integrated hand lever. Additionally, these motors incorporate a higher power output, when compared with the same design series with 2 air connections.

Motor Size 32		Flange motor				Bracket motor			
Motor, reversible by integrated hand lever	<b>type</b> order no.	<b>FM 32 SU</b> 441824 A	<b>FM 32 LU</b> 441801 A	<b>FM 32 LLUA</b> 441825 A	<b>FM 32 LLUB</b> 441826 A	<b>KM 32 SU</b> 441868 A	<b>KM 32 LU</b> 441869 A	<b>KM 32 LLUA</b> 441870 A	<b>KM 32 LLUB</b> 441871 A
Nominal-Power	kW / HP	1.9 / 2.5	1.9 / 2.5	1.9 / 2.5	1.9 / 2.5	1.9 / 2.5	1.9 / 2.5	1.9 / 2.5	1.9 / 2.5
Nominal-Speed	rpm	3400	340	170	100	3400	340	170	100
Speed (idling)	rpm	6800	680	340	200	6800	680	340	200
Nominal-Torque	Nm / in.lbs	5.3 / 47	53 / 469	107 / 947	181 / 1602	5.3 / 47	53 / 469	107 / 947	181 / 1602
Start-Torque min.	Nm / in.lbs	7.9 / 70	79 / 699	160 / 1416	271 / 2398	7.9 / 70	79 / 699	160 / 1416	271 / 2398
Air Consumption	m <sup>3</sup> /min / cfm	1.9 / 67	1.9 / 67	1.9 / 67	1.9 / 67	1.9 / 67	1.9 / 67	1.9 / 67	1.9 / 67
Weight	kg / lbs	10 / 22	15 / 33	18 / 40	18 / 40	11 / 24	16 / 35	19 / 42	19 / 42
Hose I.D.	mm / in.	15 / <sup>5</sup> / <sub>8</sub>	15 / <sup>5</sup> / <sub>8</sub>	15 / <sup>5</sup> / <sub>8</sub>	15 / <sup>5</sup> / <sub>8</sub>	15 / <sup>5</sup> / <sub>8</sub>	15 / <sup>5</sup> / <sub>8</sub>	15 / <sup>5</sup> / <sub>8</sub>	15 / <sup>5</sup> / <sub>8</sub>

Motor Size 50		Flange motor				Bracket motor			
Motor, reversible by integrated hand lever	<b>type</b> order no.	<b>FM 50 SU</b> 442135 A	<b>FM 50 LU</b> 441828 A	<b>FM 50 LLUA</b> 442103 A	<b>FM 50 LLUB</b> 442104 A	<b>KM 50 SU</b> 442140 A	<b>KM 50 LU</b> 441873 A	<b>KM 50 LLUA</b> 441874 A	<b>KM 50 LLUB</b> 441875 A
Nominal-Power	kW / HP	3.3 / 4.4	3.2 / 4.3	3.2 / 4.3	3.2 / 4.3	3.3 / 4.4	3.2 / 4.3	3.2 / 4.3	3.2 / 4.3
Nominal-Speed	rpm	3000	240	100	75	3000	240	100	75
Speed (idling)	rpm	6000	480	200	150	6000	480	200	150
Nominal-Torque	Nm / in.lbs	10 / 88	127 / 1124	305 / 2699	407 / 3602	10 / 88	127 / 1124	305 / 2699	407 / 3602
Start-Torque min.	Nm / in.lbs	15 / 133	190 / 1681	458 / 4053	610 / 5398	15 / 133	190 / 1681	458 / 4053	610 / 5398
Air Consumption	m <sup>3</sup> /min / cfm	3.6 / 127	3.6 / 127	3.6 / 127	3.6 / 127	3.6 / 127	3.6 / 127	3.6 / 127	3.6 / 127
Weight	kg / lbs	15 / 33	20 / 44	23 / 51	23 / 51	16 / 35	21 / 46	25 / 55	25 / 55
Hose I.D.	mm / in.	19 / <sup>3</sup> / <sub>4</sub>	19 / <sup>3</sup> / <sub>4</sub>	19 / <sup>3</sup> / <sub>4</sub>	19 / <sup>3</sup> / <sub>4</sub>	19 / <sup>3</sup> / <sub>4</sub>	19 / <sup>3</sup> / <sub>4</sub>	19 / <sup>3</sup> / <sub>4</sub>	19 / <sup>3</sup> / <sub>4</sub>

Motor Size 52		Flange motor				Bracket motor			
Motor, reversible by integrated hand lever	<b>type</b> order no.	<b>FM 52 SU</b> 441741 A	<b>FM 52 LU</b> 441831 A	<b>FM 52 LLUA</b> 442105 A	<b>FM 52 LLUB</b> 442106 A	<b>KM 52 SU</b> 441876 A	<b>KM 52 LU</b> 441877 A	<b>KM 52 LLUA</b> 441878 A	<b>KM 52 LLUB</b> 441879 A
Nominal-Power	kW / HP	4.6 / 6.2	4.5 / 6.0	4.5 / 6.0	4.5 / 6.0	4.6 / 6.2	4.5 / 6.0	4.5 / 6.0	4.5 / 6.0
Nominal-Speed	rpm	2800	240	100	75	2800	240	100	75
Speed (idling)	rpm	5600	480	200	150	5600	480	200	150
Nominal-Torque	Nm / in.lbs	16 / 142	180 / 1593	430 / 3805	573 / 5071	16 / 142	180 / 1593	430 / 3805	573 / 5071
Start-Torque min.	Nm / in.lbs	24 / 212	270 / 2389	645 / 5708	860 / 7611	24 / 212	270 / 2389	645 / 5708	860 / 7611
Air Consumption	m <sup>3</sup> /min / cfm	5 / 176	5 / 176	5 / 176	5 / 176	5 / 176	5 / 176	5 / 176	5 / 176
Weight	kg / lbs	17 / 37	22 / 48	25 / 55	25 / 55	18 / 40	23 / 51	27 / 59	27 / 59
Hose I.D.	mm / in.	25 / 1	25 / 1	25 / 1	25 / 1	25 / 1	25 / 1	25 / 1	25 / 1

Performance data relate to an air pressure of 6 bar (85 PSI)

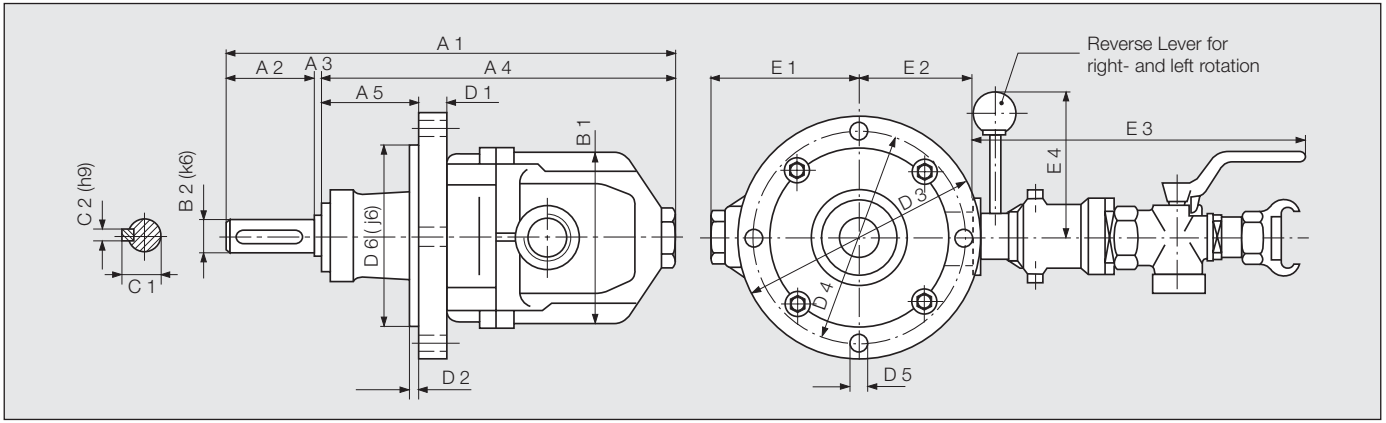

Motor Size	Type	Dimensions of Flange motor (mm)																			
		A1	A2	A3	A4	A5	B1	B2	C1	C2	D1	D2	D3	D4	D5	D6	E1	E2	E3	E4	
32	FM 32 SU	200	50	3	147	4	132	25	27.9	8	22	4	190	160	14	138	110	118	295	140	
	FM 32 LU	289	50	2	237	64	132	25	27.9	8	22	5	190	160	14	138	110	118	295	140	
	FM 32 LLUA/B	371	50	2	319	105	132	30	32.9	8	22	5	190	160	14	138	110	118	295	140	
50	FM 50 SU	245	60	3	182	5	158	30	32.9	8	22	5	220	195	14	165	108	130	295	140	
	FM 50 LU	367	60	-	307	96	158	35	38.3	10	22	5	220	195	14	165	108	130	295	140	
	FM 50 LLUA/B	437	60	-	377	114	158	40	43.1	12	22	5	220	195	14	165	108	130	295	140	
52	FM 52 SU	266	60	3	203	5	158	30	32.9	8	22	5	220	195	14	165	108	130	295	140	
	FM 52 LU	388	60	-	328	96	158	35	38.3	10	22	5	220	195	14	165	108	130	295	140	
	FM 52 LLUA/B	458	60	-	398	114	158	40	43.1	12	22	5	220	195	14	165	108	130	295	140	

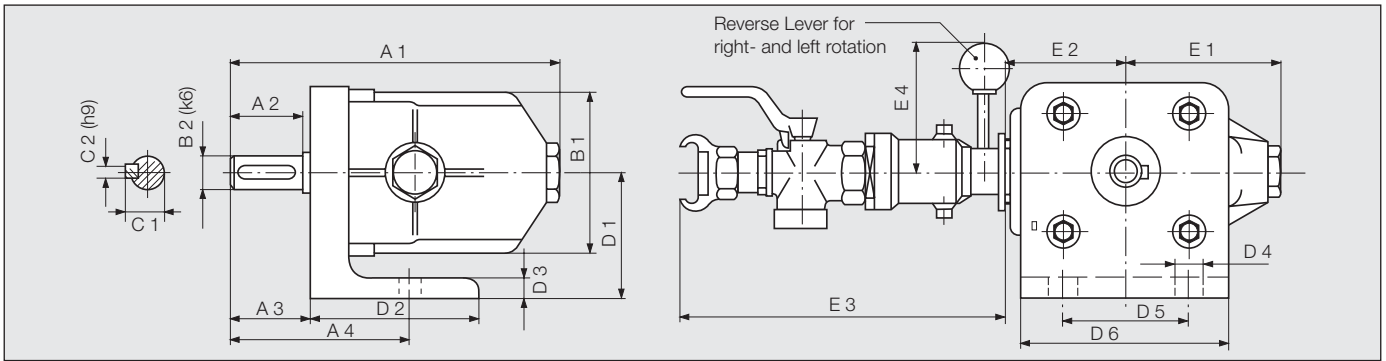

Motor Size	Type	Dimensions of Bracket motor (mm)																	
		A1	A2	A3	A4	B1	B2	C1	C2	D1	D2	D3	D4	D5	D6	E1	E2	E3	E4
32	KM 32 SU	200	50	53	118	132	25	27.9	8	105	115	13	14	90	150	110	118	295	140
50	KM 50 SU	245	60	63	143	158	30	32.9	8	120	130	13	14	116	182	108	130	295	140
52	KM 52 SU	264	60	63	143	158	30	32.9	8	120	130	13	14	116	182	108	130	295	140

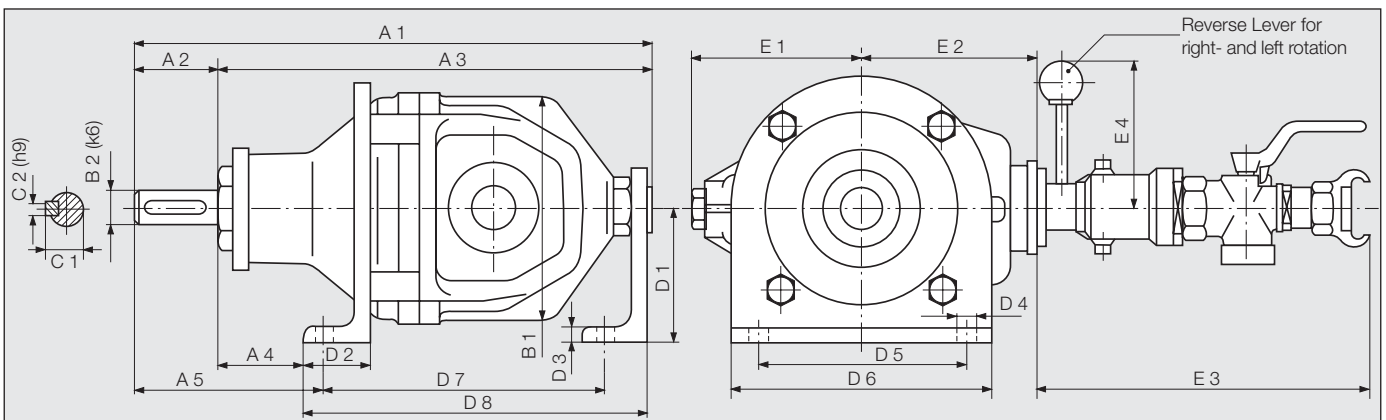

Motor Size	Type	Dimensions of Bracket motor (mm)																				
		A1	A2	A3	A4	A5	B1	B2	C1	C2	D1	D2	D3	D4	D5	D6	D7	D8	E1	E2	E3	E4
32	KM 32 LU	306	50	255	41	106	132	25	27.9	8	93	50	13	13	120	160	163	213	110	118	295	140
	KM 32 LLUA/B	386	50	336	74	139	132	30	32.9	8	93	50	13	13	120	160	210	260	110	118	295	140
50	KM 50 LU	384	60	324	66	141	161	35	38.3	10	100	50	13	13	150	190	204	254	108	131	295	140
	KM 50 LLUA/B	454	60	394	32	122	161	40	43.1	12	100	45	13	13	120	160	264	359	115	131	295	140
52	KM 52 LU	406	60	346	66	141	161	35	38.3	10	100	50	13	13	150	190	226	276	108	131	295	140
	KM 52 LLUA/B	474	60	414	32	122	161	40	43.1	12	100	45	13	13	120	160	284	379	115	131	295	140

## Technical Data

The motors in this design series can be operated in either right- or left rotation. Alternatively, the motor can also be reversed by two external 3/2-way valves or one 5/3-way valve (each with sufficiently large cross-sections).

Motor Design		Bracket motor	Bracket motor		Flange motor
Motor Size		54	55		65
Motor, reversible by external valve	<b>type</b> order no.	<b>KM 54 LX7*</b> 442397 D	<b>KM 55-16F1</b> 442767 A	<b>KM 55-7F1</b> 442767 B	<b>FM 65</b> 444200 A
Nominal-Power	kW / HP	5.1 / 6.8	9 / 12	9 / 12	18 / 24
Nominal-Speed	rpm	300	800	400	3000
Speed (idling)	rpm	600	1600	800	6000
Nominal-Torque	Nm / in.lbs	160 / 1416	107 / 947	215 / 1903	57 / 504
Start-Torque min.	Nm / in.lbs	240 / 2124	160 / 1416	320 / 2832	85 / 752
Air Consumption	m <sup>3</sup> /min / cfm	6.2 / 219	10 / 353	10 / 353	20 / 706
Weight	kg / lbs	30 / 66	36 / 79	36 / 79	53 / 117
Hose I.D.	mm / in.	25 / 1	25 / 1	25 / 1	43 / 1 3/4

Performance data relate to an air pressure of 6 bar (85 PSI)

\*) not reversible by external 3/2- or 5/3-way valve

Dimensions of Motor (mm)

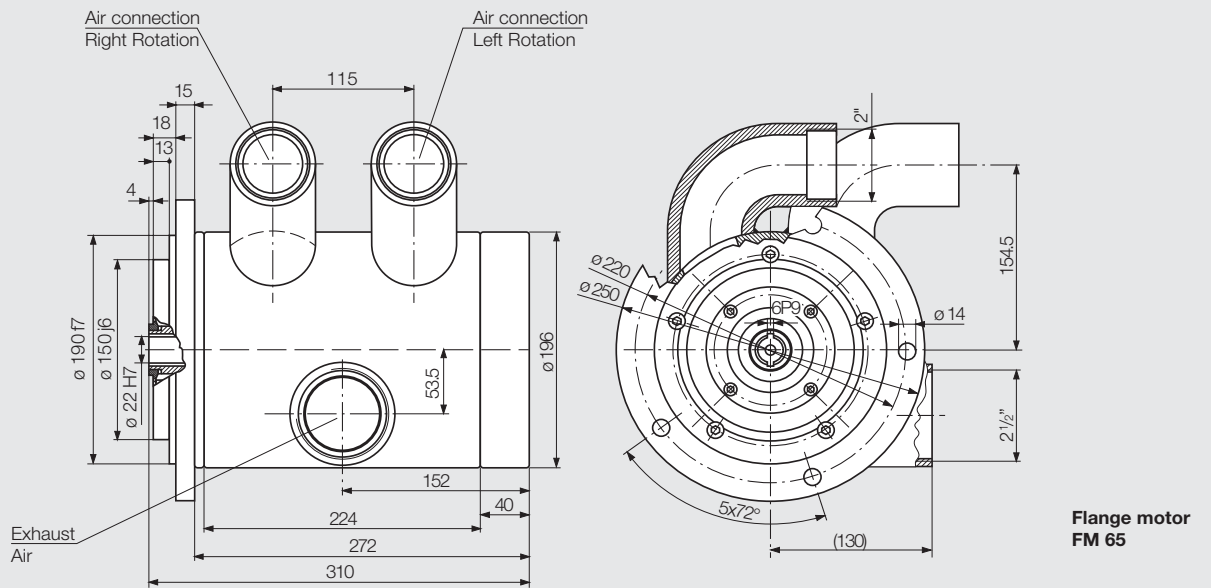
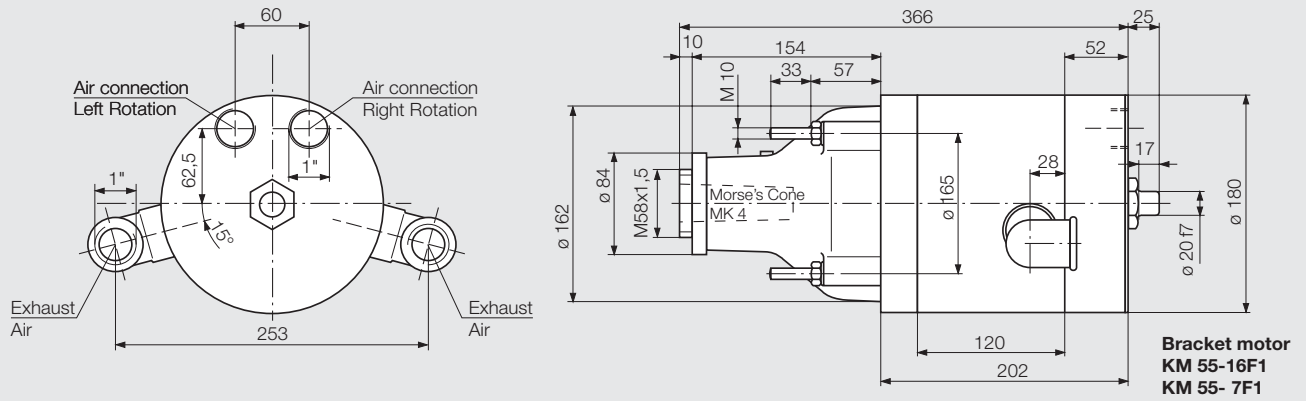
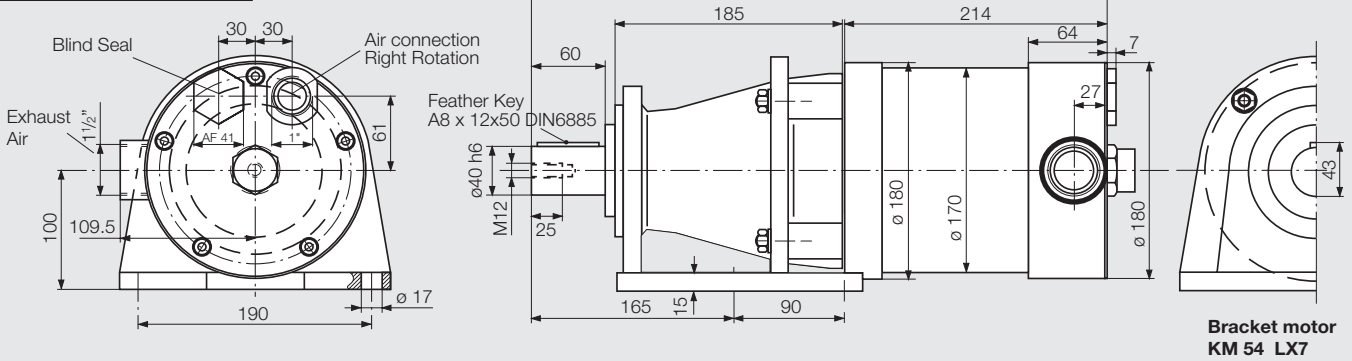

# DEPRAG

**DEPRAG SCHULZ GMBH u. CO.**

P.O. Box 1352, D-92203 Amberg, Germany  
Kurfürstenring 12-18, D-92224 Amberg  
Phone (096 21) 371-0, Fax (096 21) 371-120  
[www.deprag.com](http://www.deprag.com)  
[info@deprag.de](mailto:info@deprag.de)



CERTIFIED AS PER DIN EN ISO 9001

---